

**FANUC Series 16 $i$ -PB**  
**FANUC Series 18 $i$ -PB**  
**FANUC Series 160 $i$ -PB**  
**FANUC Series 180 $i$ -PB**

## **PARAMETER MANUAL**

- No part of this manual may be reproduced in any form.
- All specifications and designs are subject to change without notice.

The export of this product is subject to the authorization of the government of the country from where the product is exported.

In this manual we have tried as much as possible to describe all the various matters.  
However, we cannot describe all the matters which must not be done, or which cannot be done, because there are so many possibilities.  
Therefore, matters which are not especially described as possible in this manual should be regarded as "impossible".

## PREFACE

This manual describes the specialized parameters for the following model:

Product name	Abbreviation
FANUC Series 16i-PB	16i-PB
FANUC Series 18i-PB	18i-PB
FANUC Series 160i-PB	160i-PB
FANUC Series 180i-PB	180i-PB

### NOTE

For details of other parameters, refer to "Parameter Manual." Note that some functions cannot be used. For details, refer to "Descriptions (for punch press)."

The table below lists the manuals related to MODEL B of the Series 16i, Series 18i, Series 160i and Series 180i. This manual is indicated by an asterisk (\*).

**Table 1 Related Manuals**

Manual name	Specification number	
FANUC Series 16i/18i/160i/180i-PB DESCRIPTIONS	B-63682EN	
FANUC Series 16i/18i/21i/160i/180i/210i/160is/180is/210is-MODEL B CONNECTION MANUAL (Hardware)	B-63523EN	
FANUC Series 16i/18i/21i/160i/180i/210i/160is/180is/210is-MODEL B CONNECTION MANUAL (Function)	B-63523EN-1	
FANUC Series 16i/18i/160i/180i-PB CONNECTION MANUAL (Function)	B-63683EN	
FANUC Series 16i/18i/160i/180i-PB OPERATOR'S MANUAL	B-63684EN	
FANUC Series 16i/18i/21i/160i/180i/210i/160is/180is/210is-MODEL B MAINTENANCE MANUAL	B-63525EN	
FANUC Series 16i/18i/160i/180i/160is/180is-MODEL B PARAMETER MANUAL	B-63530EN	
FANUC Series 16i/18i/160i/180i-PB PARAMETER MANUAL	B-63690EN	*
FANUC Series 0i/16/18/20/21 PROGRAMMING MANUAL (Macro Compiler/Macro Executor)	B-61803E-1	



# Table of Contents

---

<b>PREFACE .....</b>	<b>1</b>
<b>1. PARAMETERS OF THE PRESS FUNCTION .....</b>	<b>1</b>
<b>2. PARAMETERS FOR THE SPEED AND LOOP GAIN SWITCH .....</b>	<b>13</b>
<b>3. PARAMETERS FOR THE NIBBLING FUNCTION .....</b>	<b>24</b>
<b>4. PARAMETERS FOR THE PATTERN FUNCTION .....</b>	<b>27</b>
<b>5. PARAMETERS FOR THE PUNCH AND LASER SWITCH .....</b>	<b>32</b>
<b>6. PARAMETERS FOR THE TURRET AXIS .....</b>	<b>33</b>
6.1 PARAMETERS FOR THE FUNCTION USED TO SET TOOL DATA .....	37
<b>7. PARAMETERS FOR C-AXIS CONTROL .....</b>	<b>40</b>
<b>8. PARAMETERS (1) FOR THE SAFETY ZONE .....</b>	<b>50</b>
<b>9. ADDITIONAL PARAMETERS FOR DI/DO SIGNALS .....</b>	<b>58</b>
<b>10.PARAMETERS FOR CANCELLING Y-AXIS GAP .....</b>	<b>59</b>
<b>11.SPEED AND SERVO PARAMETER SWITCHING PARAMETERS .....</b>	<b>62</b>
<b>12.PARAMETERS (2) FOR THE SAFETY ZONE .....</b>	<b>71</b>



## 1

## PARAMETERS OF THE PRESS FUNCTION

Address	#7	#6	#5	#4	#3	#2	#1	#0
16000	PEI	NFI	PFI			RPF	HCI	HSP

Data type: Bit

**HSP** High-speed press control is:

- 0: Disabled.
- 1: Enabled.

The following functions cannot be used:

- Servo waveform display (The correct waveform cannot be displayed while this function is being used.)
- Axis control by PMC (PMC axis cannot be controlled while this function is being used)
- Advanced preview control
- Using the simple synchronous control function for multiple pairs of axes (excluding Cs synchronization control)

**HCI** Under high-speed press control, the \*PFIN signal to complete punching for single-cycle pressing, and the \*NFIN signal to complete punching for continuous pressing are valid for:

- 0: Standard address (X004).

When this is selected, the maximum stop time, from when the punching complete signal is input until movement along an axis starts, is 7 msec.

- 1: High-speed DI address HDI0 (both \*PFIN and \*NFIN).

When this is selected, the maximum stop time, from when the punching complete signal is input until movement along an axis starts, is 3 msec.

**RPF** When the RESET key is pressed or when external reset, reset and rewind, or emergency stop is activated, the PF signal to start pressing is:

- 0: Set to 0.
- 1: Not set to 0.

PF is set to 0 only when the \*PE signal to stop pressing is set to 0.

**PFI** The logic of the \*PFIN signal to complete punching for single-cycle pressing is:

- 0: The same as the logic described in the "Connection Manual."
- 1: The reverse of the logic described in the "Connection Manual."

- NFI The logic of the \*NFIN signal to complete punching for continuous pressing is:
  - 0: The same as the logic described in the “Connection Manual.”
  - 1: The reverse of the logic described in the “Connection Manual.”
- PEI The logic of the \*PE signal to stop pressing is:
  - 0: The same as the logic described in the “Connection Manual.”
  - 1: The reverse of the logic described in the “Connection Manual.”

Address	#7	#6	#5	#4	#3	#2	#1	#0
16001	CPF	MPF	PMA	PSY	PE2	PRC	PFE	MNP

Data type: Bit

- MNP If there remains a distance to be traveled when automatic operation is halted, manual pressing or continuous manual pressing is:
  - 0: Validated.
  - 1: Invalidated.
- PFE When the PF signal to start pressing is set to 1, the absolute value of positional deviation for the X- and Y- axes:
  - 0: Must be less than or equal to the value set in parameter 16010.
  - 1: Need not be less than or equal to the value set in parameter 16010.
- PRC When the machine lock signal, MLK, is set to 1, a program check is:
  - 0: Not executed.
  - 1: Executed.

The machine position data is updated although the actual position is not changed. This setting is invalid for the machine lock signal of each axis.
- PE2 To output the PF signal to start pressing, position check is executed at intervals of:
  - 0: 8 msec.
  - 1: 2 msec.
- PSY Under simple synchronous control, the PF signal to start pressing is output:
  - 0: Irrespective of the machine coordinates of the synchronous axes.
  - 1: After it has been confirmed that the machine coordinates of the synchronous axes agree with each other.

If the machine coordinates differ, alarm 213 will be issued and the PF signal will not be output.
- PMA When the AFL signal to lock miscellaneous functions is set to 1, M code signals for forming, repositioning, and nibbling are:
  - 0: Not output to the machine.
  - 1: Output to the machine.



- MPF** In a block containing an M code, the PF signal to start pressing is:  
 0: Not set to 1.  
 1: Set to 1.  
 PF is set to 1 when movement along an axis terminates or when completion of the miscellaneous function is returned.
- CPF** At the end of the O1 group containing the G01, G02, or G03 code, the PF signal to start pressing is:  
 0: Not set to 1.  
 1: Set to 1.

Address	#7	#6	#5	#4	#3	#2	#1	#0
16002	EUP	PF9	PWB	SPR	PFB	PEM	NIP	AET

Data type: Bit

- AET** The timer for issuing the EF signal to start external operation in advance (parameter 16041) is:  
 0: Disabled.  
 1: Enabled.
- NIP** Upon the completion of punching, ITP shift is:  
 0: Performed (The delay between the completion of punching and the start of axial movement is fixed to 19 ms.)  
 1: Not performed (The delay between the completion of punching and the start of axial movement varies within a range of 11 to 19 ms.)
- PEM** MDI operation:  
 0: Does not start pressing.  
 1: Starts pressing.
- PFB** The PFB signal to start pressing is:  
 0: Enabled.  
 1: Disabled.
- SPR** The \*SPR signal to halt automatic operation B is:  
 0: Invalidated.  
 1: Validated.
- PWB** The PFWB signal to wait for the start of pressing B is:  
 0: Invalidated.  
 1: Validated.
- PF9** The time interval between setting of the PFB signal to start pressing B to 0 and setting of the PF signal to start pressing to 0 is set to the value in:  
 0: Parameter 16037.  
 1: Parameter 16038.
- EUP** By executing the external operation function, the number of punching cycles is:  
 0: Not aggregated.  
 1: Aggregated.  
 One is added when the PF signal to start pressing and the EF signal to external operation are set to 1.

Address	#7	#6	#5	#4	#3	#2	#1	#0
16003	NED	DPE	TCF			NPF		

Data type: Bit

- NPF** The G01, G02, or G03 code specified in normal direction control:  
 0: Sets PF to 1.  
 1: Does not set PF to 1.  
 Parameter NPF (No.16003, #2) is validated when parameter CPF (No.16001, #7) is set to 1.
- TCF** After the OP signal indicating that automatic operation is in progress is set from 0 to 1, the PF signal to start pressing is set to 1:  
 0: Only when a T command is found.  
 This status is the same as the status in which the PFW signal to wait for the start of pressing is set to 1.  
 1: Even if no T commands are found.
- DPE** The relationship between the \*PE signal to stop pressing and the EPE signal for ignoring the signal to stop pressing is as follows:  
 0: \*PE is always validated irrespective of the status of EPE.  
 1: \*PE is validated when EPE is set to 1, and invalidated when EPE is set to 0.
- NED** After the last positioning ends in a nibbling block, the PF signal to start pressing is set to 0:  
 0: When the contact of the \*PE signal to stop pressing is set to 0.  
 1: When the two contacts of the \*NFIN signal to complete punching for continuous pressing and the \*PE signal stop pressing are set to 0.

Address	
16008	M code for setting the forming mode
16009	M code for canceling the forming mode

Data type: Byte

Valid data range: 1 to 97

Parameter 16008 sets the M code for setting the forming mode.

Parameter 16009 sets the M code for canceling the forming mode.

Address	
16010	Upper limit of the position deviation at which PF is set to 1

Data type: Word axis

Unit of data: Units of detection

Valid data range: 0 to 32767

For each axis, parameter 16010 sets the upper limit of the positional deviation at which the PF signal to start pressing is set to 1. When the absolute value of the positional deviation does not exceed this highest limit, PF is set to 1.

Parameter 16010 is validated when parameter PFE (No. 16001, #1) is set to 1.

**NOTE**

The parameter can only be set for the X, Y, and C axes.

Address

16011

Duration for which the start of positioning is delayed

Data type: Byte axis

Unit of data: msec

Valid data range: 0 to 248

For each axis, parameter 16011 sets the duration for which the start of positioning is delayed.

**NOTE**

- 1 Only a multiple of 8 can be set for parameter 16011.
- 2 The parameter can only be set for the X, Y, and C axes.

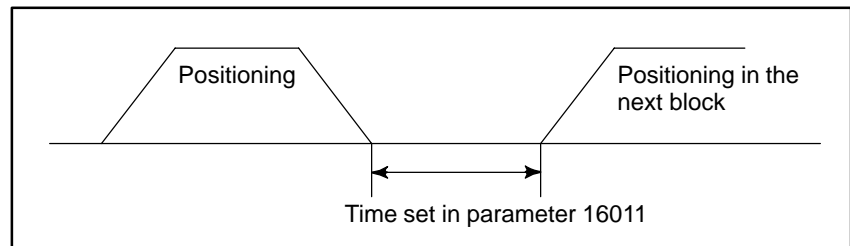

Address

16012

Time interval by which setting of PF to 1 precedes completion of positioning

Data type: Byte axis

Unit of data: msec

Valid data range: 0 to 248

For each axis, parameter 16012 sets the time interval by which setting of the PF signal to start pressing to 1 precedes completion of positioning. (Function to advance setting of the PF signal)

**NOTE**

- 1 When parameter KLV (No. 16050, #7) is set to 1, the data is invalidated. If it is invalidated, see the descriptions of parameters 16013 to 16026.
- 2 The parameter can only be set for the X, T, and C axes.

Address	
16013	Time interval by which setting of PF to 1 precedes completion of X-axis positioning for the distance of level 1
16014	Time interval by which setting of PF to 1 precedes completion of X-axis positioning for the distance of level 2
16015	Time interval by which setting of PF to 1 precedes completion of X-axis positioning for the distance of level 3
16016	Time interval by which setting of PF to 1 precedes completion of X-axis positioning for the distance of level 4
16017	Time interval by which setting of PF to 1 precedes completion of X-axis positioning for the distance of level 5
16018	Time interval by which setting of PF to 1 precedes completion of X-axis positioning for the distance of level 6
16019	Time interval by which setting of PF to 1 precedes completion of X-axis positioning for the distance of level 7

Data type: Byte

Unit of data: msec

Valid data range: 0 to  $\pm 120$

Each of these parameters set the time interval by which setting of the PF signal to start pressing to 1 precedes completion of X-axis positioning for the corresponding distance level. (Function to advance setting of PF signal)

The parameters are validated when parameter KLV (No. 16050, #7) is set to 1.

For the positioning distance, see the descriptions of parameters 16055 to 16066.

**NOTE**

If a negative value is specified, the PF signal is set to 1 when the corresponding time period elapses after the completion of the positioning.

Address

16020	Time interval by which setting of PF to 1 precedes completion of Y-axis positioning for the distance of level 1.
16021	Time interval by which setting of PF to 1 precedes completion of Y-axis positioning for the distance of level 2.
16022	Time interval by which setting of PF to 1 precedes completion of Y-axis positioning for the distance of level 3.
16023	Time interval by which setting of PF to 1 precedes completion of Y-axis positioning for the distance of level 4.
16024	Time interval by which setting of PF to 1 precedes completion of Y-axis positioning for the distance of level 5.
16025	Time interval by which setting of PF to 1 precedes completion of Y-axis positioning for the distance of level 6.
16026	Time interval by which setting of PF to 1 precedes completion of Y-axis positioning for the distance of level 7.

Data type: Byte

Unit of data: msec

Valid data range: 0 to  $\pm 120$ 

Each of these parameters set the time interval by which setting of the PF signal to start pressing to 1 precedes completion of Y-axis positioning for the corresponding distance level. (Function to advance setting of PF signal)

The parameters are validated when parameter KLV (No. 16050, #7) is set to 1.

For the positioning distance, set the descriptions of data 16055 to 16066.

**NOTE**

If a negative value is specified, the PF signal is set to 1 when the corresponding time period elapses after the completion of the positioning.

Address

16027	Time interval by which setting of PF to 1 precedes completion of C-axis positioning for the distance of level 1.
16028	Time interval by which setting of PF to 2 precedes completion of C-axis positioning for the distance of level 2.
16029	Time interval by which setting of PF to 3 precedes completion of C-axis positioning for the distance of level 3.

Data type: Byte

Unit of data: msec

Valid data range: 0 to  $\pm 120$ 

Each of these parameters set the time interval by which setting of the PF signal to start pressing to 1 precedes completion of C-axis positioning for the corresponding distance level. (Function to advance setting of PF signal)

The parameters are validated when parameter KLC (No. 16050, #4) is set to 1.

For the positioning distance, see the description of data 16140 and 16141.

**NOTE**

If a negative value is specified, the PF signal is set to 1 when the corresponding time period elapses after the completion of the positioning.

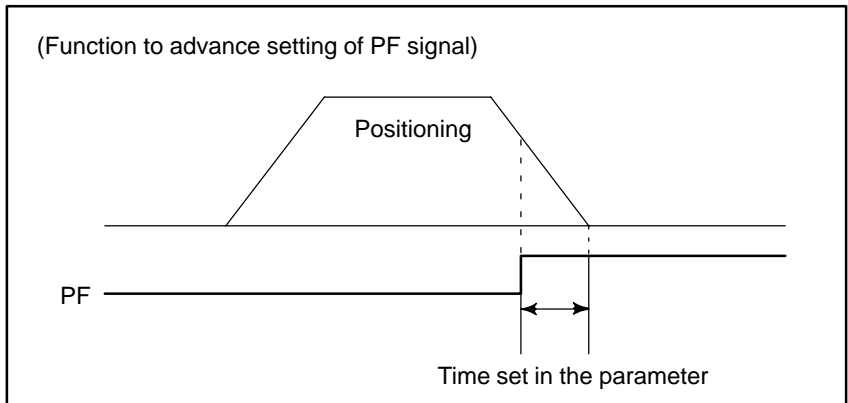

If the time set here is longer than the time required for deceleration, the PF signal is set to 1 when deceleration starts.

In simultaneous positioning for the X, Y, and C axes, the PF signal is set to 1 when the individual conditions for the X, Y, and C axes are all satisfied.

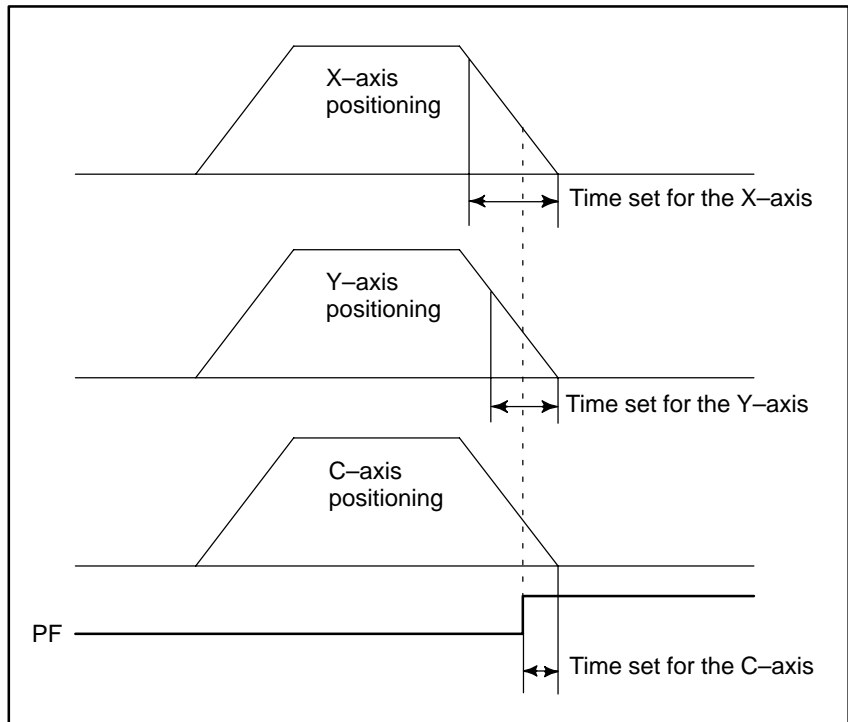

Address

16030

Time interval by which setting PF to 0 follows setting \*PE to 0 in single-cycle pressing

Data type: Byte

Unit of data: msec

Valid data range: 0 to 248

Parameter 16030 sets the time interval by which setting the PF signal to start pressing to 0 follows setting the contact of the \*PE signal to stop pressing to 0 in single-cycle pressing.

Address

16031

Time interval between completion of positioning and the start of the next block when PFL is set to 1

Data type: Byte

Unit of data: msec

Valid data range: 0 to 248

Parameter 16031 sets the time interval between completion of positioning and the start of the next block when are PFL signal to lock the start of pressing is set to 1.

Address

16032

Time interval by which setting of PF to 1 follows positioning in the forming mode

Data type: Byte

Unit of data: msec

Valid data range: 0 to 248

Parameter 16032 sets the time interval by which setting the PF signal to start pressing to 1 follows positioning in the forming mode (except for nibbling).

Address

16033

Time interval by which the start of the next block follows setting of \*PFIN to 0 in the forming mode

Data type: Byte

Unit of data: msec

Valid data range: 0 to 248

Parameter 16033 sets the time interval by which the start of the next block follows setting the contact of the \*PFIN signal to complete punching for single-cycle pressing to 0 in the forming mode.

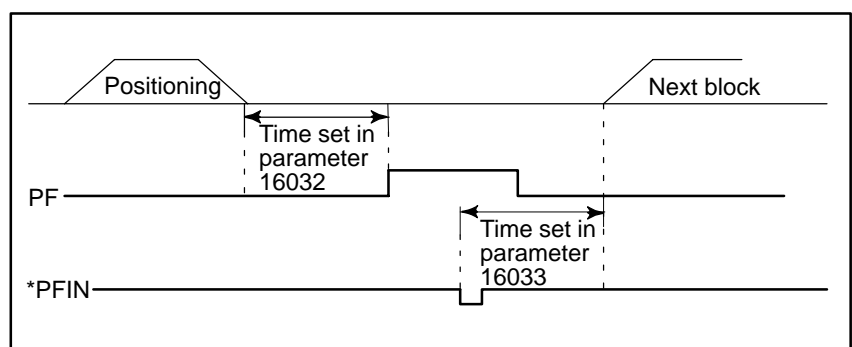

Address

16034

Time interval by which setting PF to 1 follows first positioning in nibbling

Data type: Byte

Unit of data: msec

Valid data range: 0 to 248

Parameter 16034 sets the time interval by which setting the PF signal to start pressing to 1 follows positioning at the first punch point in nibbling (nibbling by G68, G69, and M code).

Address

16035

Time interval by which the start of the next block follows setting \*NFIN to 0 at the last positioning in nibbling

Data type: Byte

Unit of data: msec

Valid data range: 0 to 248

Parameter 16035 sets the time interval by which the start of the next block follows setting the contact of the \*NFIN signal to complete punching for continuous pressing to 0 at positioning at the last punch point in nibbling (nibbling by G68, G69, and M code).

Address

16036

Minimum time interval by which setting of PF to 1 follows setting of \*PFIN to 0 in single-cycle pressing

Data type: Byte

Unit of data: msec

Valid data range: 0 to 248

Parameter 16036 sets the minimum time interval by which setting the PF signal to start pressing to 1 follows setting the contact of the \*PFIN signal to complete punching for single-cycle pressing to 0 in single-cycle pressing. After the contact of \*PFIN is set to 0, PF is set to 1 when the time set here elapses. PF is not set to 1 even if positioning for the next block completes and other conditions are satisfied before the time elapses.

Address

16037

Time interval by which setting PFB to 1 follows setting PF to 1 and setting PF to 0 follows setting PFB to 0

Data type: Byte

Unit of data: msec

Valid data range: 0 to 20

Parameter 16037 sets the time interval by which setting the PFB signal to start pressing B to 1 follows setting the PF signal to start pressing to 1 and setting PF to 0 follows setting PFB to 0.

**NOTE**

- 1 Only a multiple of 2 can be set for parameter 16037.
- 2 The parameter must be set to 0 when the PFB signal is not used.



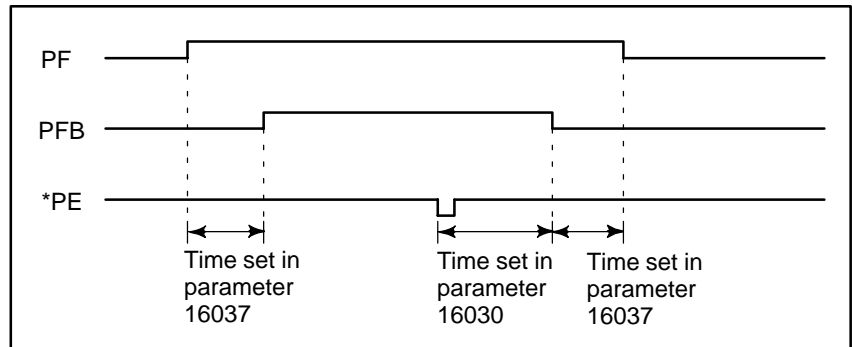

Address

16038	Time interval by which setting PF to 0 follows setting PFB to 0
-------	---

Data type: Byte

Unit of data: msec

Valid data range: 0 to 20

Parameter 16038 sets the time interval by which setting the PF signal to start pressing to 0 follows setting the PFB signal to start pressing B to 0. The data is validated when parameter PF9 (No. 16002, #6) is set to 1.

**NOTE**

Only a multiple of 2 can be set in parameter 16038.

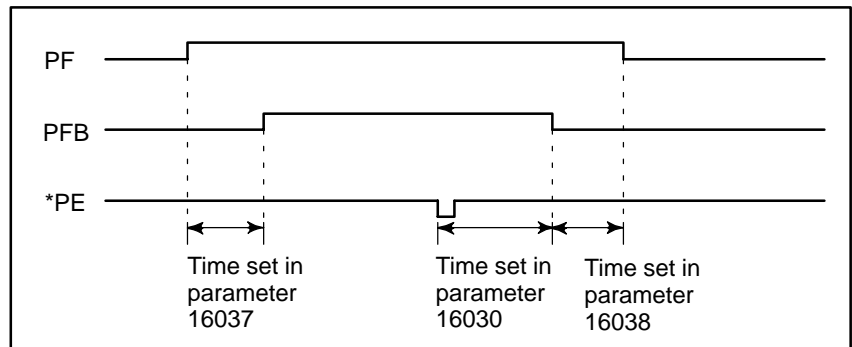

Address

16039	Time interval by which setting PF to 0 follows setting *PE to 0 in nibbling
-------	---

Data type: Byte

Unit of data: msec

Valid data range: 0 to 248

Parameter 16039 sets the time interval by which setting the PF signal to start pressing to 0 follows setting the contact of the \*PE signal to stop pressing to 0 in nibbling.

Address

16040

Time interval by which the start of the next block follows setting \*PFIN to 0

Data type: Byte

Unit of data: msec

Valid data range: 0 to 248

Parameter 16040 sets the time interval by which the start of the next block follows setting the contact of the \*PFIN signal to complete single-cycle pressing to 0 in a block where the PF signal to start pressing is set to 1 (except for the nibbling or forming mode).

Address

16041

Time interval by which setting of EF to 1 precedes the completion of positioning

Data type: Byte

Unit of data: msec

Valid data range: 0 to  $\pm 120$ 

This parameter sets the time interval by which setting of the EF signal to 1 by the external operation function precedes the completion of positioning.

If a negative value is specified, the EF signal is set to 1 when the corresponding time period elapses after the completion of positioning.

# 2

## PARAMETERS FOR THE SPEED AND LOOP GAIN SWITCH

Address	#7	#6	#5	#4	#3	#2	#1	#0
16050	KLV	PCT	CT2	KLC	NCT	N3S	PCF	G0F

Data type: Bit

**G0F** For a rapid traverse command (G00), the X-axis or Y-axis rapid traverse feedrate is set to the value:

- 0: Specified in the parameter.
- 1: Specified by the F code.

The maximum feedrate of the F command is limited to the rapid traverse feedrate in the parameter. KLV (No. 16050, #7) and LPG (No. 16051, #4) are valid.

**PCF** The X-axis or Y-axis movement mode is selected for the following blocks:

- (1) Movement to each punch point with the pattern function (G26, G76, G77, G78, etc.)
- (2) Operation in automatic repositioning (G75)
- (3) Movement to the first punch point with the nibbling function (G68, G69, and M code)
- 0: Rapid traverse is executed.
- 1: For G00, rapid traverse is executed. For G01, G02, or G03, linear interpolation cutting feed is executed.

**N3S** During nibbling, three-stage switching for constant positioning time control for the X- and Y-axes is:

- 0: Disabled
- 1: Enabled

When this parameter is set to 1, parameters No. 16800 to 16827 are also used.

**NCT** Constant control of positioning time is:

- 0: Always enabled.
- 1: Enabled only when the nibbling command is executed.

This parameter is valid when the PCT bit (bit 6 of parameter 16050) is set to 1.

**KLC** When rapid traverse is executed in automatic operation, the function to change the time constant and C-axis rapid traverse feedrate among three levels according to the positioning angle is:

- 0: Invalidated.
- 1: Validated. See the descriptions of parameters 16140 to 16147.

**CT2** In constant control of the positioning time, the times specified in parameters 16095 to 16102 are:

- 0: Not changed.
- 1: Doubled.

- PCT** Constant control of positioning time is:  
 0: Invalidated.  
 1: Validated.  
 The parameter is validated when parameter KLV (No. 16050, #7) is set to 1.  
 See the descriptions of parameters 16095 to 16102.
- KLV** When rapid traverse is executed in automatic operation, the function to change the time constant and X-axis and Y-axis rapid traverse feedrates among seven levels according to the positioning distance is:  
 0: Invalidated.  
 1: Validated. See the descriptions of data 16055 to 16094.

Address	#7	#6	#5	#4	#3	#2	#1	#0
16051	PGC		VGC	LPG	KLT			

Data type: Bit

- KLT** When rapid traverse is executed in automatic operation, the function to change the servo loop gain of position control and time constant of T-axis rapid traverse among three levels according to the indexed angle is:  
 0: Invalidated.  
 1: Validated.  
 See the descriptions of parameters 16117 to 16124.
- LPG** When rapid traverse is executed in automatic operation, the function to change the servo loop gain of X-axis and Y-axis position control among seven levels according to the positioning distance is:  
 0: Invalidated.  
 1: Validated.  
 The parameter is validated when parameter KLV (No. 16050, #7) is set to 1.  
 See the descriptions of parameters 16103 to 16116.
- VGC** During automatic operation, the velocity loop gain, position gain, and PI/IP control switching functions for the X- and Y-axes are:  
 0: Disabled  
 1: Enabled  
 When this parameter is set to 1, parameters N3S (bit 2 of No. 16050), KLV (bit 7 of No. 16050), PIN and PIP (bits 3 and 2 of No. 16054), and Nos. 16828 to 16843 are also used.
- PGC** Servo loop gains of X-axis and Y-axis position control to be used in rapid traverse and cutting feed:  
 0: Are the same.  
 1: Can be set separately. See the description of parameter 16160.

Address	#7	#6	#5	#4	#3	#2	#1	#0
16052			TJG				TCO	NJC

Data type: Bit

NJC The jog feedrate is:

- 0: Limited to the manual rapid traverse rate.
- 1: Not limited to the manual rapid traverse rate.

TCO For the T or C axis, a rapid traverse override is:

- 0: Validated.

ROV1	ROV2	T-axis or C-axis override
0	0	100%
1	0	100%
0	1	50%
1	1	50%

- 1: Invalidated. (The rapid traverse override is always 100%.)

TJG The jog override signals for the T-axis and C-axis (G233, #0 and #1) are:

- 0: Not used.
- 1: Used.

*JVT1	*JVT2	T-axis or C-axis override
1	1	25%
1	0	50%
0	1	75%
0	0	100%

Address	#7	#6	#5	#4	#3	#2	#1	#0
16053						ROM	NOV	TMO

Data type: Bit

TMO Override for a linear acceleration/deceleration time constant for rapid traverse is:

- 0: Disabled
- 1: Enabled

NOV While constant positioning time control is applied during nibbling, rapid traverse override is:

- 0: Disabled
- 1: Enabled

This parameter is valid when bit 2 (N3S) of parameter No. 16050 is set to 1.

ROM Rapid traverse override is carried out:

- 0: According to the conventional specification.
- 1: According to the specification for the 16i/18i-M.

The PF signal is issued in advance only when the override is 100%.

The constant positioning-time control function cannot be used.

Address	#7	#6	#5	#4	#3	#2	#1	#0
16054		NAZj			PINj	PIPj	2MPj	

Data type: Bit axis

**2MPj** Specifies the acceleration/deceleration duration for a rapid traverse command.

- 0: 8 ms
- 1: 2 ms

- (1) This function can be set for each axis. FANUC, however, advises against setting this function for more than four axes. If this function is set for more than four axes, the operability and CNC processing speed may be degraded considerably, depending on other specified options. In such a case, normal control cannot be guaranteed.
- (2) This function cannot be used together with the look-ahead control function.
- (3) Servo waveform data is displayed in 8 ms cycles.

The PIPj and PINj parameters are used to switch PIIP control for the ordinary machining and nibbling modes during automatic operation. They are effective only for the X- and Y-axes. They are effective if the VGC parameter (bit 5 of parameter No. 16051) is 1.

**PIPj** Specifies a speed control type for the ordinary machining mode as follows:

- 0: IP control
- 1: PI control

**PINj** Specifies a speed control type for the nibbling mode as follows:

- 0: IP control
- 1: PI control

**NAZi** Specifies whether to make a return to the reference position of the CNC controlled axis using G28 as follows:

- 0: Make a return.
- 1: Do not make a return.

Address	
16055	Distance D1 to level 1 (in mm)
16056	Distance D2 to level 2 (in mm)
16057	Distance D3 to level 3 (in mm)
16058	Distance D4 to level 4 (in mm)
16059	Distance D5 to level 5 (in mm)
16060	Distance D6 to level 6 (in mm)

Address

16061	Distance D1 to level 1 (in inches)
16062	Distance D2 to level 2 (in inches)
16063	Distance D3 to level 3 (in inches)
16064	Distance D4 to level 4 (in inches)
16065	Distance D5 to level 5 (in inches)
16066	Distance D6 to level 6 (in inches)

Data type: Two-word

Unit of data:

Increment system	IS-A	IS-B	Units
Input in millimeters	0.01	0.001	mm
Input in inches	0.001	0.0001	inch

Valid data range: 0 to 99999999

Each of the parameters set the positioning distance to use the function to change the time constant and X-axis and Y-axis rapid traverse feedrate among seven levels according to the positioning distance. (Identical values are set for the X and Y axes.)

The data is validated when parameter KLV (No. 16050, #7) is set to 1.

**NOTE**

- 1 The values set here must satisfy the following relationship:  
 $D1 < D2 < D3 < D4 < D5 < D6$ .
- 2 The values can be changed among seven levels or less. When the values are to be changed among four levels, set D4 to 99999999.

Address

16067	X-axis rapid traverse feedrate of level 1
16068	X-axis rapid traverse feedrate of level 2
16069	X-axis rapid traverse feedrate of level 3
16070	X-axis rapid traverse feedrate of level 4
16071	X-axis rapid traverse feedrate of level 5
16072	X-axis rapid traverse feedrate of level 6
16073	X-axis rapid traverse feedrate of level 7

Data type: Two-word

Unit of data:

Valid data range:

Increment system	Units of data	Valid data range
Millimeter machine	1 mm/min	30 to 240000
Inch machine	0.1 inch/min	30 to 96000

Each of the parameters set the X-axis rapid traverse feedrate for the corresponding distance.

See the descriptions of parameters 16055 to 16066.

Address

16074	X-axis rapid traverse time constant of level 1
16075	X-axis rapid traverse time constant of level 2
16076	X-axis rapid traverse time constant of level 3
16077	X-axis rapid traverse time constant of level 4
16078	X-axis rapid traverse time constant of level 5
16079	X-axis rapid traverse time constant of level 6
16080	X-axis rapid traverse time constant of level 7

Data type: Word

Unit of data: msec

Valid data range: 8 to 4000

Each of the parameters set the X-axis rapid traverse time constant for the corresponding positioning distance.

See the descriptions of parameters 16055 to 16066.

Address

16081	Y-axis rapid traverse feedrate of level 1
16082	Y-axis rapid traverse feedrate of level 2
16083	Y-axis rapid traverse feedrate of level 3
16084	Y-axis rapid traverse feedrate of level 4
16085	Y-axis rapid traverse feedrate of level 5
16086	Y-axis rapid traverse feedrate of level 6
16087	Y-axis rapid traverse feedrate of level 7

Data type: Two-word

Unit of data:

Valid data range:

Increment system	Units of data	Valid data range
Millimeter machine	1 mm/min	30 to 240000
Inch machine	0.1 inch/min	30 to 96000

Each of the parameters set the Y-axis rapid traverse feedrate for the corresponding distance.

See the descriptions of parameters 16055 to 16066.



Address

16088	Y-axis rapid traverse time constant of level 1
16089	Y-axis rapid traverse time constant of level 2
16090	Y-axis rapid traverse time constant of level 3
16091	Y-axis rapid traverse time constant of level 4
16092	Y-axis rapid traverse time constant of level 5
16093	Y-axis rapid traverse time constant of level 6
16094	Y-axis rapid traverse time constant of level 7

Data type: Word

Unit of data: msec

Valid data range: 8 to 4000

Each of the parameters set the Y-axis rapid traverse time constant for the corresponding positioning distance.

See the descriptions of parameters 16055 to 16066.

Relationship between positioning distances and data numbers

Level	Positioning distance d	X-axis		Y-axis	
		Rapid traverse feedrate	Rapid traverse time constant	Rapid traverse feedrate	Rapid traverse time constant
1	$0 < d \leq D1$	16067	16074	16081	16088
2	$D1 < d \leq D2$	16068	16075	16082	16089
3	$D2 < d \leq D3$	16069	16076	16083	16090
4	$D3 < d \leq D4$	16070	16077	16084	16091
5	$D4 < d \leq D5$	16071	16078	16085	16092
6	$D5 < d \leq D6$	16072	16079	16086	16093
7	$D6 < d$	16073	16080	16087	16094

Address

16095	X-axis positioning time of level 1 (Rapid traverse override of 100% or 75%)
16096	X-axis positioning time of level 1 (Rapid traverse override of 50% or 25%)
16097	X-axis positioning time of level 2 (Rapid traverse override of 100% or 75%)
16098	X-axis positioning time of level 2 (Rapid traverse override of 50% or 25%)

Address	
16099	Y-axis positioning time of level 1 (Rapid traverse override of 100% or 75%)
16100	Y-axis positioning time of level 1 (Rapid traverse override of 50% or 25%)
16101	Y-axis positioning time of level 2 (Rapid traverse override of 100% or 75%)
16102	Y-axis positioning time of level 2 (Rapid traverse override of 50% or 25%)

Data type: Byte

Unit of data: msec

Valid data range: 32 to 248

When constant control of the positioning time is applied, each of the parameters set the X-axis or Y-axis positioning time for the positioning distance of level one or two.

The parameters are validated when parameter KLV (No. 16050, #7) and PCT (No. 16050, #6) are set to 1.

**NOTE**

When this function is used, parameters 16067, 16068, 16074, 16075, 16081, 16082, 16088, and 16089 are invalidated. Constant control of the positioning time is applied, irrespective of the positioning distance.

Address	
16103	X-axis servo loop gain of level 1
16104	X-axis servo loop gain of level 2
16105	X-axis servo loop gain of level 3
16106	X-axis servo loop gain of level 4
16107	X-axis servo loop gain of level 5
16108	X-axis servo loop gain of level 6
16109	X-axis servo loop gain of level 7

Data type: Word

Unit of data:  $0.01 \text{ sec}^{-1}$

Valid data range: 1 to 9999

Each of the parameters set the servo loop gain of X-axis position control for the corresponding positioning distance.

See the descriptions of parameters 16055 to 16066.

Address	
16110	Y-axis servo loop gain of level 1
16111	Y-axis servo loop gain of level 2
16112	Y-axis servo loop gain of level 3
16113	Y-axis servo loop gain of level 4
16114	Y-axis servo loop gain of level 5
16115	Y-axis servo loop gain of level 6
16116	Y-axis servo loop gain of level 7

Data type: Word

Unit of data:  $0.01 \text{ sec}^{-1}$

Valid data range: 1 to 9999

Each of the parameters set the servo loop gain of Y-axis position control for the corresponding positioning distance.

See the descriptions of parameters 16055 to 16066.

Address	
16117	T-axis angle to level 1
16118	T-axis angle to level 2

Data type: Word

Unit of data: 0.1 deg

Valid data range: 0 to 3600

Each of the parameters set the indexed angle to use the function for changing the T-axis rapid traverse time constant and servo loop gain of position control among three levels according to the indexed angle.

The parameters are validated when parameter KLT (No. 16051, #3) is set to 1.

**NOTE**

The value of level 1 must be smaller than the value of level 2.

Address	
16119	T-axis rapid traverse time constant of level 1
16120	T-axis rapid traverse time constant of level 2
16121	T-axis rapid traverse time constant of level 3

Data type: Word

Unit of data: msec

Valid data range: 8 to 4000

Each of the parameters set the T-axis rapid traverse time constant to use the function for changing the T-axis rapid traverse time constant and servo loop gain of position control among three levels according to the indexed angle.

See the descriptions of parameters 16117 and 16118.

Address

16122	T-axis servo loop gain of level 1
16123	T-axis servo loop gain of level 2
16124	T-axis servo loop gain of level 3

Data type: Word

Unit of data:  $0.01 \text{ sec}^{-1}$

Valid data range: 1 to 9999

Each of the parameters set the servo loop gain of T-axis position control to use the function for changing the T-axis rapid traverse time constant and servo loop gain of position control among three levels according to the indexed angle.

See the descriptions of parameters 16117 and 16118.

Address

16140	C-axis angle to level 1
16141	C-axis angle to level 2

Data type: Two-word

Unit of data:  $0.01 \text{ deg (IS-A)}/0.001 \text{ deg (IS-B)}$

Valid data range: 0 to 99999999

Each of the parameters set the positioning angle to use the function for changing the C-axis rapid traverse feedrate and time constant among three levels according to the positioning angle.

The data is validated when parameter KLC (No. 16050, #4) is set to 1.

**NOTE**

The value of level 1 must be smaller than the value of level 2.

Address

16142	C-axis rapid traverse feedrate of level 1
16143	C-axis rapid traverse feedrate of level 2
16144	C-axis rapid traverse feedrate of level 3

Data type: Two-word

Unit of data:  $1 \text{ deg/min}$

Valid data range: 30 to 240000

Each of the parameters set the C-axis rapid traverse feedrate to use the function for changing the C-axis rapid traverse feedrate and rapid traverse time constant among three levels according to the positioning angle.

See the descriptions of parameters 16140 and 16141.

Address

16145	C-axis rapid traverse time constant of level 1
16146	C-axis rapid traverse time constant of level 2
16147	C-axis rapid traverse time constant of level 3

Data type: Word

Unit of data: msec

Valid data range: 8 to 4000

Each of the parameters set the C-axis rapid traverse to use the function for changing the C-axis rapid traverse feedrate and rapid traverse time constant among three levels according to the positioning angle.

See the descriptions of parameters 16140 and 16141.

Address

16160	Servo loop gain in cutting feed
-------	---------------------------------

Data type: Word axis

Unit of data:  $0.01 \text{ sec}^{-1}$ 

Valid data range: 1 to 9999

For each axis, the parameter sets the servo loop gain of position control in cutting feed.

The parameter is validated when parameter PGC (No. 16051, #7) is set to 1.

**NOTE**

The parameter can only be set for the X and Y axes.

# 3

## PARAMETERS FOR THE NIBBLING FUNCTION

Address	#7	#6	#5	#4	#3	#2	#1	#0
16181			NPS	SN2	NPF	NSP	NPC	NMG

Data type: Bit

**NMG** When the M code for canceling the nibbling mode (No. 16184) is specified, the G code in the 01 group is:

- 0: Not changed.
- 1: Changed to G00 (rapid traverse).

**NPC** The function to change maximum pitch in the nibbling mode between two levels is:

- 0: Not used.
- 1: Used.

The function can be executed by the SNP signal for changing nibbling between two levels or by the M code (No. 16185).

**NSP** When the \*SP signal to halt automatic operation is set to 0 in nibbling, automatic operation is:

- 0: Decelerated and halted immediately.
- 1: Halted after positioning for a nibbling pitch completes.

**NPF** In nibbling mode, a press sequence is:

- 0: Executed according to conventional signals, NBL and \*NFIN.
- 1: Executed according to signals PF, \*PFIN, and \*PE.

When this parameter is set to 1, a press sequence is executed in the same way as a sequence for single-cycle press.

**SN2** Nibbling parameter switching control using an external signal is:

- 0: Disabled
- 1: Enabled

When using this parameter, set bit 1 of parameter No. 16181 (NPC) to 0.

**NPS** While nibbling parameter switching control using an external signal is applied, stage switching is:

- 0: Performed according to the state of the external signal
- 1: Performed according to the nibbling pitch

This parameter is valid when bit 2 of parameter No. 16050 (N3S) is set to 1.

### NOTE

The nibbling pitch is checked according to the state of the external signal.

Address

16183	M code for setting the nibbling mode
-------	--------------------------------------

16184	M code for canceling the nibbling mode
-------	--

Data type: Byte

Valid data range: 1 to 255

Parameter 16183 sets the M code for setting the nibbling mode.

Address

16185	M code for setting the nibbling mode in which nibbling is changed between two levels
-------	--

Data type: Byte

Valid data range: 1 to 255

Parameter 16185 sets the M code for setting the nibbling mode in which nibbling is changed between two levels.

The data is validated when parameter NPC (No. 16181, #1) is set to 1.

**NOTE**

The M code in parameter 16184 is used to cancel the nibbling mode if set.

Address

16186	Maximum pitch for G68 or G69 (in mm)
-------	--------------------------------------

16187	Maximum pitch for G68 or G69 (in inches)
-------	--

Data type: Two-word

Unit of data:

Increment system	IS-A	IS-B	Units
Input in millimeters	0.01	0.001	mm
Input in inches	0.001	0.0001	inch

Valid data range: 1 to 99999999

Each of the parameters specifies the maximum pitch that can be specified with G01, G02, or G03 for nibbling by G68 or G69 or by an M code.

Address

16188	Maximum pitch for nibbling by the M code (in mm)
-------	--

16189	Maximum pitch for nibbling by the M code (in inches)
-------	--

Data type: Two-word

Unit of data:

Increment system	IS-A	IS-B	Units
Input in millimeters	0.01	0.001	mm
Input in inches	0.001	0.0001	inch

Valid data range: 1 to 99999999

Each of the parameters set the maximum pitch for nibbling by the M code (No. 16183).

Address

16190	Maximum pitch of the G01, G02 or G03 command for changing nibbling between two levels (in mm)
-------	---

16191	Maximum pitch of the G01, G02 or G03 command for changing nibbling between two levels (in inches)
-------	---

Data type: Two-word

Unit of data:

Increment system	IS-A	IS-B	Units
Input in millimeters	0.01	0.001	mm
Input in inches	0.001	0.0001	inch

Valid data range: 1 to 99999999

When nibbling by the M code (No. 16185) is executed or the SNP signal for changing nibbling between two levels is set to 1 while the function for changing nibbling between two levels is used, each of the parameters set the maximum nibbling pitch for the G01, G02, or G03 command.

The parameters are validated when parameter NPC (No.16181, #1) is set to 1.

Address

16192	Maximum pitch of G00 command for changing nibbling between two levels (in mm)
-------	---

16193	Maximum pitch of G00 command for changing nibbling between two levels (in inches)
-------	---

Data type: Two-word

Unit of data:

Increment system	IS-A	IS-B	Units
Input in millimeters	0.01	0.001	mm
Input in inches	0.001	0.0001	inch

Valid data range: 1 to 99999999

When nibbling by the M code (No. 16185) is executed or the SNP signal for changing nibbling between two levels is set to 1 while the function for changing nibbling between two levels is used, each of the parameters sets the maximum nibbling pitch for the G00 command.

The data is validated when parameter NPC (No.16181, #1) is set to 1.

Address

16194	Maximum distance traveled along C-axis in nibbling
-------	--

Data type: Two-word

Unit of data: 0.01 deg (IS-A)/0.001 deg (IS-B)

Valid data range: 1 to 99999999

The parameter sets the maximum distance traveled along the C-axis for G68 and the nibbling mode.



# 4

## PARAMETERS FOR THE PATTERN FUNCTION

Address	#7	#6	#5	#4	#3	#2	#1	#0
16200	UVW	ABM	MUR					UVC

Data type: Bit

**UVC** In the reset status, the macro stored under a U or V macro number is:

- 0: Deleted.
- 1: Not deleted.

### NOTE

When the parameter is set to 1, two or more macros with identical numbers may often be stored. It takes a long time to process the storage of macros.

**MUR** U or V macro numbers are handled:

- 0: According to the standard specifications.
- 1: According to the following specifications.
  - (1) Changing a macro number
    - Storage and execution: U01 to U69 and U90 to U99
    - Storage: U70 to U79
    - Representation of several macros: U80 to U89
  - (2) Macro numbers are handled in the same way as when parameter 16206 of the G73 or G74 command for taking multiple workpieces is set to 2.

### NOTE

Parameter 16206 is invalidated.

**ABM** To store and call a pattern, addresses A and B:

- 0: Are used.
- 1: Are not used. (The A and B axes can be used.)

**UVW** To execute a macro function, addresses U, V, and W:

- 0: Are used.
- 1: Are not used. (The U, V, and W axes can be used.)

Address	#7	#6	#5	#4	#3	#2	#1	#0
16201	MSA	AWP	IPA	APR	MLP	MPC		LIP

Data type: Bit

- LIP** In the block immediately following setting a local coordinate system (G52), an incremental command specifies an incremental value from:
- 0: The origin of the local coordinate system.
  - 1: The current tool position.
- MPC** When the number of machined workpieces is counted in multiple-workpiece machining:
- 0: The number of actually machined workpieces is counted.
  - 1: The number is incremented by one when complete machining or remainder machining is executed (but not when trial machining is executed).
- MLP** Setting for taking multiple workpieces depends on:
- 0: The set parameter (No.16206).
  - 1: A signal (MLP1 or MLP2) input from the PMC machine.
- APR** Upon reset, the repositioning compensation value is:
- 0: Not cleared.
  - 1: Added to the workpiece coordinate system and cleared.
- IPA** Although positioning is to be executed in the block immediately following execution of the pattern function (including G68 or G69), only a command for either the X- or Y-axis is specified. Movement to the pattern reference point:
- 0: Is not executed for the axis which is not specified.
  - 1: Is executed for the axis which is not specified.
- AWP** When a workpiece coordinate system is specified, automatic coordinate system setting is executed as designed for:
- 0: The FANUC Series 16.  
When manual return to the reference position is completed, the origin of the coordinate system is shifted by the amount set for the selected workpiece coordinate system (G54 to G59).
  - 1: The FANUC Series 0-P.  
When manual return to the reference position is completed, the coordinates of the automatic coordinate system setting are shifted by the amount set for the selected workpiece coordinate system (G54 to G59).
- MSA** When the MUR bit (bit 5 of parameter 16200) is set to 1, the machining pattern set for multiple-workpiece machining is:
- 0: Disabled. When this is selected, the value of parameter 16206 is always assumed to be 2.
  - 1: Enabled.

Address	#7	#6	#5	#4	#3	#2	#1	#0
16202								AIP

Data type: Bit

**AIP** Specifies the condition for the share-proof command (G86).  
 0: Alarm 4506 is issued when  $I \geq 1.5P$  ( $I \geq 1.5wl$ ).  
 (Conventional specification)  
 1: Alarm 4506 is issued when  $I \geq P$  ( $I \geq wl$ ).

Address	#7	#6	#5	#4	#3	#2	#1	#0
16203							ACD	PCU

Data type: Bit

**PCU** The number of machined workpieces is:  
 0: Counted by an MDI command.  
 1: Not counted by an MDI command.

**ACD** A program block causing a PS alarm is:  
 0: Not displayed.  
 1: Displayed.  
 See the description of parameter 16229.

Address	#7	#6	#5	#4	#3	#2	#1	#0
16204				PDG		BKR		

Data type: Bit

**BKR** The first automatic repositioning command (G75) that sets automatic operation signal OP from 0 to 1 uses:  
 0: The values set in parameters 16209 and 16210 as the clearance and amount of return for the Y-axis.  
 (The clearance and amount of return are identical values.)  
 1: The values set in parameters 16209 and 16210 as the clearance for the Y-axis, and the values set in parameters 16211 and 16212 as the amount of return.  
 (The clearance and amount of return are different values.)

**PDG** On the graphic screen, a program being drawn is:  
 0: Not displayed.  
 1: Displayed.  
 This parameter is invalid when the 9-inch CRT is being used.

Address	
16206	Machining pattern when multiple workpieces are taken

Data type: Byte

Valid data range: 0 to 3

Parameter 16206 sets a machining pattern when multiple workpieces are taken.

0: A program without the G73 or G74 command for machining when multiple workpieces are taken is used.

**NOTE**

Alarm 4539 is issued if the G73 or G74 command is found with this setting.

- 1: A program containing the G73 or G74 command is used and test machining is executed.
- 2: A program containing the G73 or G74 command is used and the remaining processing is executed after test machining.
- 3: A program containing the G73 or G74 command is used and the entire machining is executed.

Address

16207	M code for clamping a workpiece
-------	---------------------------------

16208	M code for releasing the workpiece
-------	------------------------------------

Data type: Byte

Valid data range: 1 to 255

Parameter 16207 sets the M code for clamping a workpiece. Parameter 16208 sets the M code for releasing the workpiece.

In blocks between the M code for clamping a workpiece and the M code for releasing the workpiece, the distances traveled along the X-axis and Y-axis are not taken into account in the workpiece coordinate system. The PF signal to start pressing is not set to 1.

Address

16209	Clearance and amount of return for the Y axis in automatic repositioning (in mm)
-------	--

16210	Clearance and amount of return for the Y axis in automatic repositioning (in inches)
-------	--

Data type: Two-word

Unit of data:

Increment system	IS-A	IS-B	Units
Input in millimeters	0.01	0.001	mm
Input in inches	0.001	0.0001	inch

Valid data range: 1 to  $\pm 99999999$ 

Each of the parameters sets the clearance and amount of return for the Y-axis in automatic repositioning (G75).

Address

16211	Amount of return for the Y-axis in automatic repositioning (G75, in millimeters)
-------	--

16212	Amount of return for the Y-axis in automatic repositioning (G75, in inches)
-------	---

Data type: Two-word

Unit of data:

Increment system	IS-A	IS-B	Units
Input in millimeters	0.01	0.001	mm
Input in inches	0.001	0.0001	inch

Valid data range: 1 to  $\pm 99999999$

These parameters specify the amount of return for the Y-axis in automatic repositioning (G75).

The clearance is specified in conventional parameters 16209 and 16210. These parameters are valid when the BKR bit (bit 2 of parameter 16204) is set to 1.

Address

16228	Number of characters that can be stored for a U or V macro function
-------	---

Data type: Byte

Valid data range:

Setting value	Number of macro storage characters
0	3200
1	11008
2	22272
3	27072

Address

16229	Color code setting for alarm block display
-------	--

Data type: Byte

Valid data range:

Setting value	Alarm color
1	Red
2	Green
3	Yellow
4	Blue
5	Pink
6	Light blue
7	White
Others	Pink

This parameter specifies the color code in which a program block causing a PS alarm is displayed. A block causing an overtravel or servo alarm is not displayed.

# 5

## PARAMETERS FOR THE PUNCH AND LASER SWITCH

Address	#7	#6	#5	#4	#3	#2	#1	#0
16240			RLM					ALA

Data type: Bit

**ALA** Switching between the punching mode and laser mode is:  
 0: Invalidated.  
 1: Validated.

**RLM** When the power is turned on or in the clear status, the machine is set in the:  
 0: Punching mode.  
 1: Leser mode.

Address	#7	#6	#5	#4	#3	#2	#1	#0
16241					ILM			

Data type: Bit

**ILM** In a block other than cutting feed blocks or blocks between the two cutting feed blocks when the laser mode is selected, the next block is started:

0: After the following is checked: The specified speed is reduced to zero and the machine reaches the specified position. (A position check is carried out.)

1: After checking that the specified speed is reduced to zero. (No position check is carried out.)

The parameters are validated when parameter ALA (No. 16240, #0) is set to 1.

In punching mode, the NCI bit (bit 5 of parameter 1601) is valid.

Address	
16244	M code for setting the punching mode
16245	M code for setting te leser mode

Data type: Byte

Valid data range: 0 to 255

Each of the parameters set the M code for setting the punching mode or leser mode.

The parameters are validated when parameter ALA (No. 16240, #0) is set to 1.

# 6

## PARAMETERS FOR THE TURRET AXIS

Address	#7	#6	#5	#4	#3	#2	#1	#0
16260		TLP	TNM	TCL			BST	

Data type: Bit

**BST** The function used to output a T code beforehand is:

- 0: Disabled.
- 1: Enabled.

**TCL** The T axis is:

- 0: Not controlled by the CNC machine.
- 1: Controlled the CNC machine.

**TNM** When machine lock signal MLK and the TNG signal for ignoring a T command are on, whether the number following address T is cataloged as a tool number is:

- 0: Not checked.
- 1: Checked.

### NOTE

Generally, the tool number is not checked when the TNG signal is set to 1.

**TLP** In positioning by the T-axis command, a shift from the current position to a specified position is executed:

- 0: In the direction in which required rotation angle is smaller.
- 1: Linearly.

### NOTE

The parameters are validated when parameter TCL (No. 16260 #4) is set to 1.

Address	#7	#6	#5	#4	#3	#2	#1	#0
16262	MBT	DTF	TNA	TND	TDP	PWT	JGT	NTD

Data type: Bit

- NTD** The tool data input screen is:
- 0: Displayed.
  - 1: Not displayed.
- JGT** On the position display screen in jog mode, a T code (tool number) is:
- 0: Not displayed by a signal input from the PMC.
  - 1: Displayed by a signal (addresses G234 to G237) input from the PMC.
- PWT** When the power is turned on, the T code (tool number) on the position display screen is:
- 0: Set to 0.
  - 1: Represented by signal input from the PMC machine (addresses G234 to G237).
- TDP** On the position screen, a T code is:
- 0: Not displayed.
  - 1: Displayed.
- This parameter is valid when the TCL bit (bit 4 of parameter 16260) is set to 1 and when the NDPx bit (bit 0 of parameter 3115) is set to 0.
- TND** When the T-axis position is displayed,
- 0: The current position is indicated in units of minimum travel increments.
  - 1: The number of the tool at the current position is indicated. This is validated when TDP (No. 16262, #3) is set to 1.
- TNA** When a tool number which is not cataloged is specified,
- 0: Alarm 4692 is issued.
  - 1: No alarm are issued but a T code is output.
- This must be specified when a T code with five or more digits is specified and TCL (No. 16260, #4) is set to 1.
- DTF** When T codes are specified in automatic operation, a TF signal for reading the code of the tool function and the tool function code signal are output:
- 0: For each T code.
  - 1: For the first T code command when the machine enters the status in which automatic operation is started from the status in which automatic operation is halted or stopped. For the second and subsequent T code commands specified until the machine returns to the status in which automatic operation is halted or stopped, the TF signal and tool function code signal are output only when the T code signal is different from the previous one.
- MBT** In a block in which a T code is specified, buffering is:
- 0: Executed.
  - 1: Not executed.



Address	#7	#6	#5	#4	#3	#2	#1	#0
16263	NDA	IDX			ROF	TOF	ATO	OFM

Data type: Bit

- OFM** In a block containing a T command, the tool position is compensated:
- 0: Even if there is no movement along an axis.
  - 1: Only when there is movement along an axis. If a block does not contain any movements along an axis, the compensation is executed in the next block containing movement along an axis.
- ATO** The tool position is compensated:
- 0: Only when a tool command is specified.
  - 1: According to the T code currently specified, even if no tool commands are specified.
- TOF** The function for compensating the tool position is:
- 0: Invalidated.
  - 1: Validated.
- Specify a tool position compensation value on the tool input screen.
- ROF** At reset, compensation of tool position is:
- 0: Not canceled.
  - 1: Canceled.
- IDX** The tool position is not compensated in a block in which no movement along an axis occurs. In the next block containing movement along an axis the tool position is compensated:
- 0: For each T code.
  - 1: Only for T codes with which turret indexing is not executed.
- This is validated when parameter OFM (No. 16263, #0) is set to 1.
- NDA** If a T command is specified in normal direction mode:
- 0: An alarm is issued (alarm No. 4606).
  - 1: An alarm is not issued.
- If a multi-tool command is specified, however, an alarm is issued.

Address	
16265	Total number of tools to be used

Data type: Word

Valid data range: 0 to 136

This parameter specifies the total number of tools to be used by the tool function. If T-axis control is selected (TCL bit (bit 4 of parameter 16260) is set to 1), the total number should include the number of tools for which T-axis control (turret index) is not executed. This parameter can be specified on the tool input screen. The tool numbers to be used should be specified on the tool input screen.

Address

16266	Number of tools for which T-axis control is executed
-------	--

Data type: Word

Valid data range: 0 to 136

This parameter specifies the number of tools for which T-axis control (turret index) is executed. This parameter is valid when the TCL bit (bit 4 of parameter 16260) is set to 1. The parameter can be specified on the tool input screen.

Address

16267	Reference-position tool number under T-axis control
-------	---

Data type: Word

Valid data range: 0 to 9999

This parameter specifies the tool number to be selected upon reference position return for the T-axis. This parameter is valid when the TCL bit (bit 4 of parameter 16260) is set to 1. The parameter can be specified on the tool input screen.

Address

16268	T-axis travel for each rotation of the turret
-------	---

Data type: Two-Word

Unit to data: Least command increment for the T-axis

Valid data range: 0 to 99999999

This parameter specifies the total T-axis travel for each rotation of the turret. This parameter is valid when the TCL bit (bit 4 of parameter 16260) is set to 1. The parameter can be specified using the tool input screen. The T-axis machine position (index position) for each tool to be used should be specified using the tool input screen.

Address

16269	Punching count for all tools (low-order)
-------	--

16270	Punching count for all tools (high-order)
-------	---

Data type: Two-Word

Valid data range: 0 to 99999999

These parameters preset the punching count for all tools to be used. Parameter 16269 can be preset on the tool input screen.

## 6.1 PARAMETERS FOR THE FUNCTION USED TO SET TOOL DATA

Address	#7	#6	#5	#4	#3	#2	#1	#0
16280	UTL	UTS	UCT	UPC	UTC	UOY	UOX	UT8

Data type: Bit

This parameter is valid when the function used to set tool data is specified. In the following description, n represents the number of tools to be stored.

- UT8** As a tool number:  
 0: Up to eight digits can be input. (n 4-byte numbers)  
 1: Up to four digits can be input. (n 2-byte numbers)
- UOX** A tool position compensation value along the X-axis is:  
 0: Not stored.  
 1: Stored. See the description of the OX4 bit (bit 1 of parameter 16281).
- UOY** A tool position compensation value along the Y-axis is:  
 0: Not stored.  
 1: Stored. See the description of the OY4 bit (bit 2 of parameter 16281).
- UTC** Under T-axis control, the machine position on the T-axis is:  
 0: Not stored.  
 1: Stored. The valid data range is 0 to 99999999. (n 4-byte values)

### NOTE

When T-axis control is used (TCL bit (bit 4 of parameter 16260) is 1), this bit should be set to 1.

- UPC** The punching count of an individual tool is:  
 0: Not stored.  
 1: Stored. See the description of the PC4 bit (bit 4 of parameter 16281).

### NOTE

When the tool life management function is used, this bit should be set to 1.

- UCT** Tool numbers for changing tools are:  
 0: Not stored.  
 1: Stored. The number of digits is the same as that for the UT8 bit (bit 0 of parameter 16280).
- UTS** A graphic tool figure is:  
 0: Not stored.  
 1: Stored. (n 13-byte values)

- UTL The tool life management data is:
- 0: Not stored.
  - 1: Stored. The data is stored in the same way as for the PC4 bit (bit 4 of parameter 16281).

Address	#7	#6	#5	#4	#3	#2	#1	#0
16281				PC4		OY4	OX4	

Data type: Bit

This parameter is valid when the function to set tool data is specified. In the following description, n represents the number of tools to be stored.

- OX4 For the tool position compensation value along the X-axis:
- 0: n four-byte values can be stored. The valid data range is 0 to  $\pm 99999999$ .
  - 1: n two-byte values can be stored. The valid data range is  $-32768$  to  $+32767$ .
- OY4 For the tool position compensation value along the Y-axis:
- 0: n four-byte values can be stored. The valid data range is 0 to  $\pm 99999999$ .
  - 1: n two-byte values can be stored. The valid data range is  $-32768$  to  $+32767$ .
- PC4 For the punching count of individual tools:
- 0: n four-byte values can be stored. The valid data range is 0 to 99999999.
  - 1: n two-byte values can be stored. The valid data range is 0 to 65536.

Address	#7	#6	#5	#4	#3	#2	#1	#0
16282		MTS	CMT		MTR	MOY	MOX	

Data type: Bit

This parameter is valid when the function used to set tool data is specified. In the following description, m represents the number of subtools stored for a multi-tool.

- MOX The tool position compensation value along the X-axis for a multi-tool is:
- 0: Not stored.
  - 1: Stored. See the description of the MX4 bit (bit 1 of parameter 16283).
- MOY The tool position compensation value along the Y-axis for a multi-tool is:
- 0: Not stored.
  - 1: Stored. See the description of the MY4 bit (bit 2 of parameter 16283).
- MTR The radius of a multi-tool is:
- 0: Not stored.
  - 1: Stored. The valid data range is 0 to 99999999. (m 4-byte values)
- CMT The tool numbers for a multi-tool:
- 0: Are the magazine number plus subtool number. When this is selected, m equals n (number of tools stored).
  - 1: Consist of the magazine number and subtool number, which are separately stored. (m 2-byte numbers)

MTS The graphic tool figure for a multi-tool is:

0: Not stored.

1: Stored. (n 13-bytes data items)

**NOTE**

This bit is valid when the CMT bit (bit 5 of parameter 16282) is set to 1.

Address	#7	#6	#5	#4	#3	#2	#1	#0
16283						MY4	MX4	

Data type: Bit

This parameter is valid when the function used to set tool data is specified. In the following description, m represents the number of subtools stored for a multi-tool.

MX4 For the tool position compensation value along the X-axis for a multi-tool:

0: m four-byte values can be specified. The valid data range is 0 to  $\pm 99999999$ .

1: m two-byte values can be specified. The valid data range is  $-32768$  to  $+32767$ .

MY4 For the tool position compensation value along the Y-axis for a multi-tool:

0: m four-byte values can be specified. The valid data range is 0 to  $\pm 99999999$ .

1: m two-byte values can be specified. The valid data range is  $-32768$  to  $+32767$ .

Address	
16284	Number of tools to be stored

Data type: Word

Valid data range: 0 or later

This parameter specifies the number of tools to be stored for the function used to set tool data.

Address	
16285	Number of digits in the tool number of an subtool for a multi-tool

Data type: Word

Valid data range: 0 to 4

This parameter specifies the number of digits that can be specified for the tool number of an subtool for which multiple tool control is executed by the function used to set tool data.

Address	
16286	Number of subtools for a multi-tool

Data type: Word

Valid data range: 0 to 249

This parameter specifies the number of subtools for which multiple tool control is executed by the function used to set tool data.

# 7

## PARAMETERS FOR C–AXIS CONTROL

Address	#7	#6	#5	#4	#3	#2	#1	#0
16360	CBR		CIP	ACS	MAB	MAI		SYN

Data type: Bit

**SYN** C–axis synchronous control is:

- 0: Disabled.
- 1: Enabled.

**MAI** The function for compensating the C–axis position is:

- 0: Invalidated.
- 1: Validated.

**MAB** The function B for compensating the C–axis position is:

- 0: Invalidated.
- 1: Validated.

**ACS** Under C–axis synchronous control, synchronization is:

- 0: Disabled.
- 1: Enabled.

**CIP** In G01, G02, and G03 modes, a C–axis command is:

- 0: Disabled
- 1: Enabled

**CBR** For a tool for which C–axis control can be executed, a C–axis backlash compensation value is:

- 0: Not separately specified.
- 1: Separately specified.

The tool numbers of those tools for which C–axis control can be executed are specified in parameters 16370 to 16389.

Address	#7	#6	#5	#4	#3	#2	#1	#0
16362	NRC		CRM	CMO	G92	CNT	CR0	RCO

Data type: Bit

- RCO** At reset, compensation of C-axis position is:  
 0: Not canceled.  
 1: Canceled.
- CR0** When reference position return is performed for the C-axis:  
 0: Moves to the zero point of the machine coordinate system.  
 1: Moves to the zero point of the workpiece coordinate system.
- CNT** If a T code with which turret indexing is not executed is specified when the C axis is not at the reference point, the machine is:  
 0: Moved along the C-axis to the reference point.  
 1: Not moved along the C-axis to the reference point.  
 This is validated when parameter CRM (No. 16362, #5) is set to 0. The T code with which turret indexing is not executed must be cataloged.
- G92** G92 command for C-axis control is:  
 0: Invalidated.  
 1: Validated.
- CMO** In positioning for a C-axis command, a shift from the current position to a specified position is executed:  
 0: In the direction in which the required rotation angle is smaller.  
 1: Linearly.
- CRM** According to a T command, the machine is:  
 0: Moved along the C-axis to the reference point.  
 1: Not moved along the C-axis to the reference point.
- NRC** According to the command of automatic return to the reference point (G28), the machine is:  
 0: Moved along the C-axis to the reference point.  
 1: Not moved along the C-axis to the reference point.  
 This is validated when parameter CRM (No. 16362, #5) is set to 0.

Address	#7	#6	#5	#4	#3	#2	#1	#0
16363			C2N	SML	NDC		NDB	G91

Data type: Bit

- G91** For C-axis control, a G91 command is:  
 0: Disabled  
 1: Enabled
- NDB** Positioning under normal direction control is carried out:  
 0: According to the conventional specification.  
 1: By handling the C-axis angle immediately before the beginning of the normal direction control mode, as an offset value.

- NDC Positioning under normal direction control is carried out:  
 0: According to the conventional specification.  
 1: By handling the C-axis angle immediately before the beginning of the normal direction control mode, as the direction normal to the next traveling direction.
- SML The T-axis/C-axis simultaneous control function is:  
 0: Disabled.  
 1: Enabled.
- C2N The name of C2-axis with C axis simultaneous control is:  
 0: "C".  
 1: Set to the parameter No.1020..

Address

16364	Upper limit of error under C-axis synchronous control
-------	---

Data type: Word

Unit to data: Units of detection

Valid data range: 0 to 32767

When the absolute value of the position error between the C<sub>1</sub>-axis and C<sub>2</sub>-axis exceeds the value set in this parameter under C-axis synchronous control, alarm 4603 occurs. This parameter is valid when the SYN bit (bit 0 of parameter 16360) is set to 1.

Address

16365	Upper limit of error under C-axis synchronous control (during continuous pressing)
-------	--

Data type: Word

Unit to data: Units of detection

Valid data range: 0 to 32767

When the absolute value of the position error between the C<sub>1</sub>-axis and C<sub>2</sub>-axis exceeds the value set in this parameter while continuous pressing signal NBL is set to 1, alarm 4603 occurs. This parameter is valid when the SYN bit (bit 0 of parameter 16360) is set to 1.

Address

16368	Maximum compensation in C-axis synchronization
-------	--

Data type: Word

Unit to data: Units of detection

Valid data range: 0 to 65536

This parameter specifies the maximum compensation in C-axis synchronization under C-axis synchronous control. If an actual compensation value exceeds this value, a large error alarm occurs in the stop state or during travel. This parameter is valid when the ACS bit (bit 4 of parameter 16360) is set to 1.



Address	
16370	Number of tool 1 for which C-axis control can be executed
16371	Number of tool 2 for which C-axis control can be executed
16372	Number of tool 3 for which C-axis control can be executed
16373	Number of tool 4 for which C-axis control can be executed
16374	Number of tool 5 for which C-axis control can be executed
16375	Number of tool 6 for which C-axis control can be executed
16376	Number of tool 7 for which C-axis control can be executed
16377	Number of tool 8 for which C-axis control can be executed
16378	Number of tool 9 for which C-axis control can be executed
16379	Number of tool 10 for which C-axis control can be executed
16380	Number of tool 11 for which C-axis control can be executed
16381	Number of tool 12 for which C-axis control can be executed
16382	Number of tool 13 for which C-axis control can be executed
16383	Number of tool 14 for which C-axis control can be executed
16384	Number of tool 15 for which C-axis control can be executed
16385	Number of tool 16 for which C-axis control can be executed
16386	Number of tool 17 for which C-axis control can be executed
16387	Number of tool 18 for which C-axis control can be executed
16388	Number of tool 19 for which C-axis control can be executed
16389	Number of tool 20 for which C-axis control can be executed

Data type: Word

Valid data range: 0 to 9999

Each of the parameters set the number of a tool for which C-axis control can be executed.

Address	
16390	C-axis backlash 1
16391	C-axis backlash 2
16392	C-axis backlash 3
16393	C-axis backlash 4
16394	C-axis backlash 5
16395	C-axis backlash 6
16396	C-axis backlash 7
16397	C-axis backlash 8
16398	C-axis backlash 9
16399	C-axis backlash 10
16400	C-axis backlash 11
16401	C-axis backlash 12
16402	C-axis backlash 13
16403	C-axis backlash 14
16404	C-axis backlash 15
16405	C-axis backlash 16
16406	C-axis backlash 17
16407	C-axis backlash 18
16408	C-axis backlash 19
16409	C-axis backlash 20

Data type: Word

Unit to data: Detection Unit

Valid data range: -9999 to +9999

Each of these parameters specifies a C-axis backlash for each index (C<sub>1</sub>-axis backlash under C-axis synchronous control). The parameter values correspond to the tool numbers specified in parameters 16370 to 16389, respectively. The parameters are valid when the CBR bit (bit 7 of parameter 16360) is set to 1. When these parameters are valid, the C-axis backlash specified in parameter 1852 is invalid.

Address	
16410	C <sub>2</sub> axis backlash 1
16411	C <sub>2</sub> axis backlash 2
16412	C <sub>2</sub> axis backlash 3
16413	C <sub>2</sub> axis backlash 4
16414	C <sub>2</sub> axis backlash 5
16415	C <sub>2</sub> axis backlash 6
16416	C <sub>2</sub> axis backlash 7
16417	C <sub>2</sub> axis backlash 8
16418	C <sub>2</sub> axis backlash 9
16419	C <sub>2</sub> axis backlash 10
16420	C <sub>2</sub> axis backlash 11
16421	C <sub>2</sub> axis backlash 12
16422	C <sub>2</sub> axis backlash 13
16423	C <sub>2</sub> axis backlash 14
16424	C <sub>2</sub> axis backlash 15
16425	C <sub>2</sub> axis backlash 16
16426	C <sub>2</sub> axis backlash 17
16427	C <sub>2</sub> axis backlash 18
16428	C <sub>2</sub> axis backlash 19
16429	C <sub>2</sub> axis backlash 20

Data type: Word

Unit to data: Detection Unit

Valid data range: -9999 to +9999

Each of these parameters specifies a C<sub>2</sub>-axis backlash for each index. The parameter values correspond to the tool numbers specified in parameters 16370 to 16389, respectively. These parameters are valid when both the SYN and CBR bits (bits 0 and 7 of parameter 16360) are set to 1. When these parameters are valid, the C-axis backlash specified in parameter 1852 is invalid.

Address	
16430	C-axis position compensation 1 to use function for compensating the C-axis position
16431	C-axis position compensation 2 to use function for compensating the C-axis position
16432	C-axis position compensation 3 to use function for compensating the C-axis position
16433	C-axis position compensation 4 to use function for compensating the C-axis position
16434	C-axis position compensation 5 to use function for compensating the C-axis position
16435	C-axis position compensation 6 to use function for compensating the C-axis position
16436	C-axis position compensation 7 to use function for compensating the C-axis position
16437	C-axis position compensation 8 to use function for compensating the C-axis position
16438	C-axis position compensation 9 to use function for compensating the C-axis position
16439	C-axis position compensation 10 to use function for compensating the C-axis position
16440	C-axis position compensation 11 to use function for compensating the C-axis position
16441	C-axis position compensation 12 to use function for compensating the C-axis position
16442	C-axis position compensation 13 to use function for compensating the C-axis position
16443	C-axis position compensation 14 to use function for compensating the C-axis position
16444	C-axis position compensation 15 to use function for compensating the C-axis position
16445	C-axis position compensation 16 to use function for compensating the C-axis position
16446	C-axis position compensation 17 to use function for compensating the C-axis position
16447	C-axis position compensation 18 to use function for compensating the C-axis position
16448	C-axis position compensation 19 to use function for compensating the C-axis position
16449	C-axis position compensation 20 to use function for compensating the C-axis position

Data type: Two-Word

Unit to data: 0.01 deg (IS-A) /0.001 deg (IS-B)

Valid data range: 0 to  $\pm 99999999$

Each of the parameters set the C-axis position compensation (C<sub>1</sub>-axis position compensation in C-axis synchronous control) to use the function for compensating the C-axis position.

These compensated values correspond to the tool numbers set in parameters 16370 to 16389.

The values validated when parameter MAI (No. 16360, #2) is set to 1.

Address	
16450	C <sub>2</sub> -axis position compensation 1 to use function for compensating the C-axis position
16451	C <sub>2</sub> -axis position compensation 2 to use function for compensating the C-axis position
16452	C <sub>2</sub> -axis position compensation 3 to use function for compensating the C-axis position
16453	C <sub>2</sub> -axis position compensation 4 to use function for compensating the C-axis position
16454	C <sub>2</sub> -axis position compensation 5 to use function for compensating the C-axis position
16455	C <sub>2</sub> -axis position compensation 6 to use function for compensating the C-axis position
16456	C <sub>2</sub> -axis position compensation 7 to use function for compensating the C-axis position
16457	C <sub>2</sub> -axis position compensation 8 to use function for compensating the C-axis position
16458	C <sub>2</sub> -axis position compensation 9 to use function for compensating the C-axis position
16459	C <sub>2</sub> -axis position compensation 10 to use function for compensating the C-axis position
16460	C <sub>2</sub> -axis position compensation 11 to use function for compensating the C-axis position
16461	C <sub>2</sub> -axis position compensation 12 to use function for compensating the C-axis position
16462	C <sub>2</sub> -axis position compensation 13 to use function for compensating the C-axis position
16463	C <sub>2</sub> -axis position compensation 14 to use function for compensating the C-axis position
16464	C <sub>2</sub> -axis position compensation 15 to use function for compensating the C-axis position
16465	C <sub>2</sub> -axis position compensation 16 to use function for compensating the C-axis position
16466	C <sub>2</sub> -axis position compensation 17 to use function for compensating the C-axis position
16467	C <sub>2</sub> -axis position compensation 18 to use function for compensating the C-axis position
16468	C <sub>2</sub> -axis position compensation 19 to use function for compensating the C-axis position
16469	C <sub>2</sub> -axis position compensation 20 to use function for compensating the C-axis position

Data type: Two-Word

Unit to data: 0.01 deg (IS-A) /0.001 deg (IS-B)

Valid data range: 0 to ± 99999999

Each of these parameters specifies a C<sub>2</sub>-axis position compensation value for the C-axis position compensation function. The parameter values correspond to the tool numbers specified in parameters 16370 to 16389. These parameters are valid when both the SYN and MAI bits (bits 0 and 2 of parameter 16360) are set to 1.

# 8

## PARAMETERS (1) FOR THE SAFETY ZONE

Address	#7	#6	#5	#4	#3	#2	#1	#0
16500	YSF		SAT					SF0

Data type: Bit

SF0 The safety zone of type:

0: A is used.

1: B is used.

### NOTE

When type B is used, punching is inhibited in punching mode and entry is inhibited in laser mode.

SAT When punching is inhibited in the safety zone, the block in which a T command is specified is checked:

0: In advance.

1: After the FIN signal to complete the T command has been received.

YSF When a safety zone check is executed, the inhibited area along the Y axis extends from the values set in parameters 16507, 16510, 16513, and 16516:

0: In the negative direction.

1: In the positive direction.

Address	#7	#6	#5	#4	#3	#2	#1	#0
16501	SZ8	SZ7	SZ6	SZ5	SZ4	SZ3	SZ2	SZ1

Data type: Bit

SZ<sub>j</sub> When a safety zone check is executed, in the #<sub>j</sub> (j=1 to 8) area,

0: An entry is inhibited.

1: Punching is inhibited.

### NOTE

To use SZ5 to SZ8, the safety zone area extension function is necessary.



Address	#7	#6	#5	#4	#3	#2	#1	#0
16502	SOF	ACZ	ZNO	SZ1	GSZ	ZIO	SZC	MDP

Data type: Bit

- MDP** On the safety zone setting display,  
 0: The workpiece coordinate system is indicated.  
 1: The machine coordinate system is indicated.
- SZC** On the safety zone setting display, the data for:  
 0: Any zone can be changed.  
 1: Those zones to be set automatically (parameter 16534) can be changed.
- ZIO** When the safety zone is automatically set by an external signal, the position of a workpiece holder is detected according to:  
 0: The on and off states of the SAFZ signal used to detect the position of a workpiece holder.  
 1: The on state of the SAFZ signal used to detect the position of a workpiece holder.
- GSZ** On the graphic screen, the safety zone is checked according to the position of a workpiece holder:  
 0: Specified on the safety zone screen.  
 1: Specified by graphic parameters.  
 (On the graphic screen, this check is executed in an area that is not related to the actual machining check.)
- SZI** Data set on the safety zone setting display is:  
 0: Invalidated.  
 1: Validated.
- ZNO** In the safety zone area setting screen of the safety zone B specification, :  
 0: Number of zone and other number than number of zone can be inputted.  
 1: Number of zone can be inputted.
- ACZ** The function used to prevent interference between workpiece holders of:  
 0: Type A is used.  
 1: Type B is used.
- SOF** In the safety zone check, tool position compensation is:  
 0: Not considered.  
 1: Considered.

Address	#7	#6	#5	#4	#3	#2	#1	#0
16503			T16	SF8				

Data type: Bit

- SF8** The number of safety zones to be used is:  
 0: Up to 4.  
 1: Up to 8.  
 At automatic safety-zone setting, workpiece holders are successively set with the mechanical position relationship of #n < #(n+1), starting from #1.  
 This parameter is valid if the safety zone area extension function is specified.

T16 The number of tool areas to be used is:  
 0: Up to 12.  
 1: Up to 16.  
 This parameter is valid if the safety zone area extension function is specified.

Address

16505	Positive X coordinate for safety zone 1
16506	Negative X coordinate for safety zone 1
16507	Y coordinate for safety zone 1
16508	Positive X coordinate for safety zone 2
16509	Negative X coordinate for safety zone 2
16510	Y coordinate for safety zone 2
16511	Positive X coordinate for safety zone 3
16512	Negative X coordinate for safety zone 3
16513	Y coordinate for safety zone 3
16514	Positive X coordinate for safety zone 4
16515	Negative X coordinate for safety zone 4
16516	Y coordinate for safety zone 4

Data type: Two-Word

Unit to data:

Increment system	IS-A	IS-B	Units
Millimeter machine	0.01	0.001	mm
Inch machine	0.001	0.0001	inch

Valid data range: 0 to ± 99999999

Each set of the parameters specify safety zone 1, 2, 3, or 4.

**NOTE**

- 1 The values set for zone #n must be smaller than those set for zone #n + 1. (n: 1 to 3)
- 2 Zeros must be specified for zones which need not be specified.
- 3 If any of the +X, -X, and Y coordinates are set to 0 for an area, that area is invalid.

Address

16517	Size of tool area 1 in the X direction for the safety zone function
16518	Size of tool area 1 in the Y direction for the safety zone function
16519	Size of tool area 2 in the X direction for the safety zone function
16520	Size of tool area 2 in the Y direction for the safety zone function
16521	Size of tool area 3 in the X direction for the safety zone function
16227	Size of tool area 3 in the Y direction for the safety zone function
16523	Size of tool area 4 in the X direction for the safety zone function
16524	Size of tool area 4 in the Y direction for the safety zone function
16525	Size of tool area 5 in the X direction for the safety zone function
16526	Size of tool area 5 in the Y direction for the safety zone function
16527	Size of tool area 6 in the X direction for the safety zone function
16528	Size of tool area 6 in the Y direction for the safety zone function
16529	Size of tool area 7 in the X direction for the safety zone function
16530	Size of tool area 7 in the Y direction for the safety zone function
16531	Size of tool area 8 in the X direction for the safety zone function
16532	Size of tool area 8 in the Y direction for the safety zone function

Data type: Two-Word

Unit to data:

Increment system	IS-A	IS-B	Units
Millimeter machine	0.01	0.001	mm
Inch machine	0.001	0.0001	inch

Valid data range: 0 to 99999999

The parameters set 12 tool areas for the safety zone function.

Refer to parameters No. 16551 to No. 16558

**NOTE**

A tool area is selected by signals SZTS0 to SZTS3 input from a PMC machine.

Address

16533	Distance between the position detector of the workpiece holder and the punch
-------	--

Data type: Two-Word

Unit to data:

Increment system	IS-A	IS-B	Units
Millimeter machine	0.01	0.001	mm
Inch machine	0.001	0.0001	inch

Valid data range: 0 to  $\pm 99999999$ 

The parameter sets the distance between the position detector of the workpiece holder and punch.

The sign of the value set in the parameter corresponds to the direction the machine travels along the X-axis, assuming the punch position as zero.

Address

16534	Number of zones to be detected for automatic setting
-------	--

Data type: Byte

Unit to data: Piece

Valid data range: 0 to 8

This parameter specifies the number of zones to be detected for automatic setting of a safety zone by an external signal.

**NOTE**

This parameter must be specified when automatic setting is executed.

Address

16535	Retraction position from the X-axis reference position for automatic setting
-------	--

Data type: Two-Word

Unit to data:

Increment system	IS-A	IS-B	Units
Millimeter machine	0.01	0.001	mm
Inch machine	0.001	0.0001	inch

Valid data range: 0 to  $\pm 99999999$ 

This parameter specifies a clearance from the X-axis reference position for automatic setting of a safety zone by means of an external signal.

**NOTE**

Specify a position that is sufficiently distant to allow the speed at which the position of a workpiece holder is detected to become stable.

Address

16536

X-axis rapid traverse rate for automatic setting

Data type: Two-Word

Unit to data:

Increment system	Units of data	Valid data range
Millimeter machine	1 mm/min	30 to 240000
Inch machine	0.1 inch/min	30 to 9600

This parameter specifies an X-axis rapid traverse rate for automatic setting of a safety zone by an external signal.

**NOTE**

When this parameter is set to 0, the feedrate along the X-axis for automatic detection equals the manual rapid traverse rate.

Address

16537

X-axis rapid traverse time constant for automatic setting

Data type: Word

Unit to data: msec

Valid data range: 8 to 4000

This parameter specifies an X-axis rapid traverse time constant for the automatic setting of a safety zone by an external signal.

**NOTE**

When this parameter is set to 0, the X-axis time constant for automatic detection equals the time constant for manual rapid traverse.

Address

16538

Lower limit of position error for movement along the X-axis for automatic setting

16539

Upper limit of position error for movement along the X-axis for automatic setting

Data type: Two-Word

Unit to data: Units of detection

Valid data range: 0 to 99999999

These parameters specify the lower and upper limits, for the position error for movement along the X-axis, for the automatic setting of a safety zone by an external signal. These parameters must be specified for automatic setting.

**NOTE**

The values of these parameters must satisfy the following condition: Parameter 16538 < Parameter 16539

Address

16540	Width of workpiece holder 1 along the X-axis for automatic setting
16541	Width of workpiece holder 2 along the X-axis for automatic setting
16542	Width of workpiece holder 3 along the X-axis for automatic setting
16543	Width of workpiece holder 4 along the X-axis for automatic setting

Data type: Two-Word

Unit to data:

Increment system	IS-A	IS-B	Units
Millimeter machine	0.01	0.001	mm
Inch machine	0.001	0.0001	inch

Valid data range: 0 to 99999999

Each of the parameters specifies the width of a workpiece holder along the X-axis for the automatic setting of a safety zone by an external signal. The parameter values correspond to safety zones 1 to 4, specified in parameters 16505 to 16516, respectively.

When automatic setting is executed, these parameters must be set.

Address

16551	X dimension of tool area 9 for the safety zone function
16552	Y dimension of tool area 9 for the safety zone function
16553	X dimension of tool area 10 for the safety zone function
16554	Y dimension of tool area 10 for the safety zone function
16555	X dimension of tool area 11 for the safety zone function
16556	Y dimension of tool area 11 for the safety zone function
16557	X dimension of tool area 12 for the safety zone function
16558	Y dimension of tool area 12 for the safety zone function

Data type: Two-Word

Unit to data:

Increment system	IS-A	IS-B	Units
Millimeter machine	0.01	0.001	mm
Inch machine	0.001	0.0001	inch

Valid data range: 0 to 99999999

The parameters set 12 tool areas for the safety zone function.

Refer to parameters No. 16517 to No. 16532

**NOTE**

A tool area is selected by signals SZTS0 to SZTS3 input from a PMC machine.

Address

16559	Width of tool area along the X-axis for the function used to prevent interference between workpiece holders
-------	---

16560	Width of tool area along the Y-axis for the function used to prevent interference between workpiece holders
-------	---

Data type: Two-Word

Unit to data:

Increment system	IS-A	IS-B	Units
Millimeter machine	0.01	0.001	mm
Inch machine	0.001	0.0001	inch

Valid data range: 0 to 99999999

Each of the parameters is specified to add a margin to the tool area when interference between the tool area (parameters 16517 to 16532) and safety zone area (parameters 16505 to 16516) is checked, to output the WHAL signal (F231, #5), by the function used to prevent interference between workpiece holders. The parameter value is added to the tool area width when interference is checked.

Address

16561	Compensation value used by the function used to prevent interference between workpiece holders
-------	--

Data type: Two-Word

Unit to data:

Increment system	IS-A	IS-B	Units
Millimeter machine	0.01	0.001	mm
Inch machine	0.001	0.0001	inch

Valid data range: 0 to 99999999

This parameter specifies a compensation value for retraction along the Y-axis when the function used to prevent interference between workpiece holders of type B is used. This parameter is valid when the ACZ bit (bit 6 of parameter 16502) is set to 1.

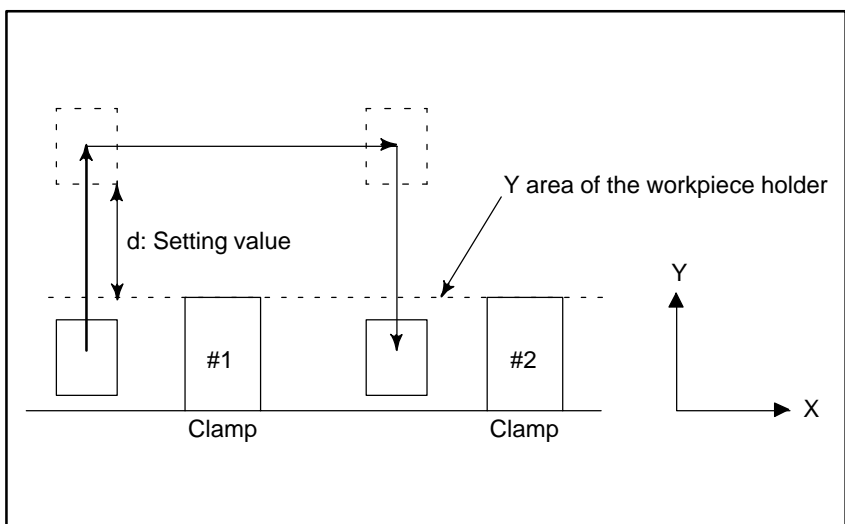

# 9

## ADDITIONAL PARAMETERS FOR DI/DO SIGNALS

Address

16600	Width for the second reference position on each axis
16601	Width for the third reference position on each axis
16602	Width for the fourth reference position on each axis

Data type: Word

Unit to data:

Increment system	IS-A	IS-B	Units
Millimeter machine	0.01	0.001	mm
Inch machine	0.001	0.0001	inch

Valid data range: 0 to 65535

The parameters specify the width for the second, third, or fourth reference position of the machine coordinate system. The second, third, or fourth reference position signal is output within the range shown below:

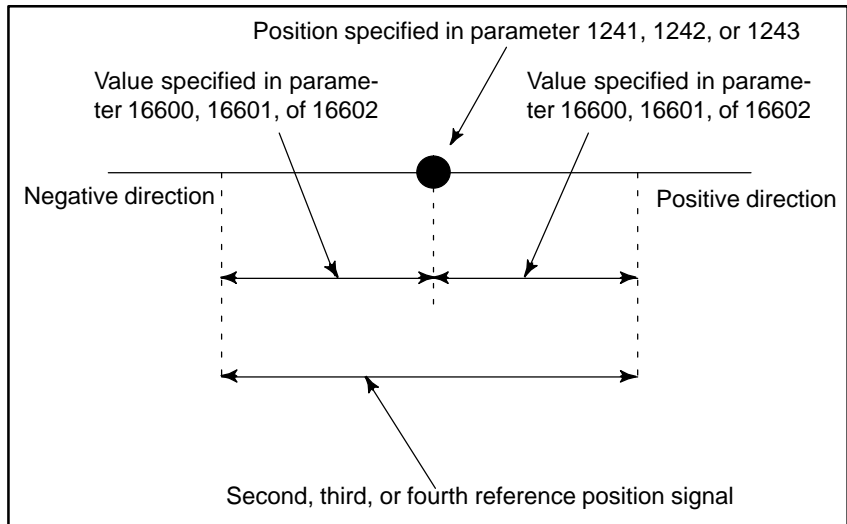

**NOTE**

For a rotation axis, the specified reference position output range must not include 0 of the machine coordinate system.



# 10

## PARAMETERS FOR CANCELLING Y-AXIS GAP

Address

16610	M code 1 for cancelling the Y-axis gap
16611	M code 2 for cancelling the Y-axis gap
16612	M code 3 for cancelling the Y-axis gap
16613	M code 4 for cancelling the Y-axis gap
16614	M code 5 for cancelling the Y-axis gap

Data type: Word

Valid data range: 0 to 65535

Each of the parameters specifies an M code to cancel the difference between the Y coordinates of the workpiece coordinate system and machine coordinate system using therepositioning command. (Up to 5 codes can be specified.) When the parameters are set to 0, the function used to cancel the Y-axis gap is disabled.

Address	
16680	Position of machine zero point 1 on T-axis
16681	Position of machine zero point 2 on T-axis
16682	Position of machine zero point 3 on T-axis
16683	Position of machine zero point 4 on T-axis
16684	Position of machine zero point 5 on T-axis
16685	Position of machine zero point 6 on T-axis
16686	Position of machine zero point 7 on T-axis
16687	Position of machine zero point 8 on T-axis
16688	Position of machine zero point 9 on T-axis
16689	Position of machine zero point 10 on T-axis
16690	Position of machine zero point 11 on T-axis
16691	Position of machine zero point 12 on T-axis
16692	Position of machine zero point 13 on T-axis
16693	Position of machine zero point 14 on T-axis
16694	Position of machine zero point 15 on T-axis
16695	Position of machine zero point 16 on T-axis

Data type: Two-Word

Unit to data: Least command increment for T-axis

Valid data range: 0 to 99999999

When the machine coordinate of the T-axis matches a position specified in parameters 16680 to 16695, the corresponding signal RP1T to RP16T (F244, F245) is output.

Address	#7	#6	#5	#4	#3	#2	#1	#0
16747								SUV

Data type: Bit

This parameter can be changed using the setting screen.

SUV In the reset state, the macros stored under U or V macro numbers are:

0: Deleted.

1: Not deleted.

This parameter is valid when the UVC bit (bit 0 of parameter 16200) is set to 1.

Address	#7	#6	#5	#4	#3	#2	#1	#0
16748								NUV

Data type: Bit

NUV Specifies the macro UV storage format.

0: Complies with the conventional specification.

1: Executes only character storage processing.

# 11

## SPEED AND SERVO PARAMETER SWITCHING PARAMETERS

Address

16800	Nibbling pitch for first stage (metric input)
16801	Nibbling pitch for second stage (metric input)
16802	Nibbling pitch for first stage (inch input)
16803	Nibbling pitch for second stage (inch input)

Data type: Two-word

Units of data:

Increment system	IS-A	IS-B	Units
Metric input	0.01	0.001	mm
Inch input	0.001	0.0001	inch

Valid data range: 0 to 99999999

When using three-stage switching for constant positioning time control for the X- and Y-axes during nibbling, use these parameters to set the nibbling pitches (common to the X- and Y-axes).

The value set for the first stage must be smaller than that set for the second stage.

If the third stage is not used, set 99999999 for the second stage.

Address

16804	First stage positioning time for X-axis
16805	Second stage positioning time for X-axis
16806	Third stage positioning time for X-axis
16807	First stage positioning time for Y-axis
16808	Second stage positioning time for Y-axis
16809	Third stage positioning time for Y-axis

Data type: Byte

Units of data: msec

Valid data range: 0 to 254

When using three-stage switching for constant positioning time control for the X- and Y-axes during nibbling, use these parameters to set the positioning times.

Address	
16810	PF output time prior to end of first stage positioning for X-axis
16811	PF output time prior to end of second stage positioning for X-axis
16812	PF output time prior to end of third stage positioning for X-axis
16813	PF output time prior to end of first stage positioning for Y-axis
16814	PF output time prior to end of second stage positioning for Y-axis
16815	PF output time prior to end of third stage positioning for Y-axis

Data type: Byte

Units of data: msec

Valid data range: -128 to 120

When using three-stage switching for constant positioning time control for the X- and Y-axes during nibbling, use these parameters to set the time during which PF is to be output prior to the end of positioning.

These parameters are valid when bit 3 (NPF) of parameter No. 16181 is set to 1.

Address	
16816	First stage position gain for X-axis
16817	Second stage position gain for X-axis
16818	Third stage position gain for X-axis
16819	First stage position gain for Y-axis
16820	Second stage position gain for Y-axis
16821	Third stage position gain for Y-axis

Data type: Word

Units of data:  $0.01 \text{ sec}^{-1}$

Valid data range: 1 to 9999

When using three-stage switching for constant position gain control for the X- and Y-axes during nibbling, use these parameters to set the position gains.

These parameters are valid when bit 4 (LPG) of parameter No. 16051 is set to 1.

Address	
16822	Velocity loop integral gain for first stage
16823	Velocity loop integral gain for second stage
16824	Velocity loop integral gain for third stage

Data type: Word axis

Valid data range: 1 to 32767

When using three-stage switching for constant position gain control for the X- and Y-axes during nibbling, use these parameters to set the velocity loop integral gains. (Equivalent to parameter No. 2043)

Only the settings for the X- and Y-axes are valid.

These parameters are valid when bit 5 (VCG) of parameter No. 16051 is set to 1.

Address	
16825	Velocity loop proportional gain for first stage
16826	Velocity loop proportional gain for second stage
16827	Velocity loop proportional gain for third stage

Data type: Word axis

Valid data range: -1 to 32767

When using three-stage switching for constant position gain control for the X- and Y-axes during nibbling, use these parameters to set the velocity loop proportional gains. (Equivalent to parameter No. 2044)

Only the settings for the X- and Y-axes are valid.

These parameters are valid when bit 5 (VCG) of parameter No. 16051 is set to 1.

Address	
16828	Velocity loop integral gain for first stage
16829	Velocity loop integral gain for second stage
16830	Velocity loop integral gain for third stage
16831	Velocity loop integral gain for fourth stage
16832	Velocity loop integral gain for fifth stage
16833	Velocity loop integral gain for sixth stage
16834	Velocity loop integral gain for seventh stage

Data type: Word axis

Valid data range: 1 to 32767

When using seven-stage velocity loop gain switching, use these parameters to set the velocity loop integral gains. (Equivalent to parameter No. 2043)

Only the settings for the X- and Y-axes are valid.

Address	
16835	Velocity loop proportional gain for first stage
16836	Velocity loop proportional gain for second stage
16837	Velocity loop proportional gain for third stage
16838	Velocity loop proportional gain for fourth stage
16839	Velocity loop proportional gain for fifth stage
16840	Velocity loop proportional gain for sixth stage
16841	Velocity loop proportional gain for seventh stage

Data type: Word axis

Valid data range: -1 to 32767

When using seven-stage velocity loop gain switching, use these parameters to set the velocity loop proportional gains. (Equivalent to parameter No. 2044)

Only the settings for the X- and Y-axes are valid.

Address	
16842	Position gain switching speed (ordinary machining)
16843	Position gain switching speed (nibbling)

Data type: Word

Valid data range: -1 to 32767

Set the maximum speed at which the position gain is doubled during automatic operation in ordinary machining mode and nibbling mode. (Equivalent to parameter No. 2028)

Only the settings for the X- and Y-axes are valid.

These parameters are valid when bit 5 (VCG) of parameter No. 16051 is set to 1 and either or both of bits 7 (KLV) and 2 (N3S) of parameter No. 16050 are set to 1.

Address	Bit No.							
	#7	#6	#5	#4	#3	#2	#1	#0
16844	KL2j	PT2j	TM2j	LP2j				

Data type: Bit axis

When using the following parameters, set all of KLV, PCT, CT2, and KLC of parameter No. 16050 and LPG and KLT of parameter No. 16051 to 0.

The following parameters are invalid for an axis controlled as a PMC axis.

**LP2j** For rapid traverse during automatic operation, seven-stage servo loop gain switching, based on the positioning distance, for position control for each axis is:

- 0: Disabled
- 1: Enabled

This parameter is valid when KL2j is set to 1.  
See also parameters No. 16882 to 16888.

**TM2j** For constant positioning time control, the times set in parameters No. 16878 to 16881 are:

- 0: Used as is
- 1: Doubled

**PT2j** Constant positioning time control is:

- 0: Disabled
- 1: Enabled

This parameter is valid when KL2j is set to 1.  
See also the explanations of parameters No. 16878 to 16881.

**KL2j** For rapid traverse during automatic operation, seven-stage rapid traverse rate and time constant switching, based on the positioning distance, for each axis is:

- 0: Disabled
- 1: Enabled

See also parameters No. 16845 to 16877.



Address

16845	Distance D1 up to first stage (metric input)
16846	Distance D2 up to second stage (metric input)
16847	Distance D3 up to third stage (metric input)
16848	Distance D4 up to fourth stage (metric input)
16849	Distance D5 up to fifth stage (metric input)
16850	Distance D6 up to sixth stage (metric input)
16851	Distance D1 up to first stage (inch input)
16852	Distance D2 up to second stage (inch input)
16853	Distance D3 up to third stage (inch input)
16854	Distance D4 up to fourth stage (inch input)
16855	Distance D5 up to fifth stage (inch input)
16856	Distance D6 up to sixth stage (inch input)

Data type: Two-word

Units of data:

Increment system	IS-A	IS-B	Units
Metric input	0.01	0.001	mm
Inch input	0.001	0.0001	inch
Rotary axis	0.01	0.001	deg

Valid data range: 0 to 99999999

When using seven-stage rapid traverse rate and time constant switching based on the positioning distance, use these parameters to set the positioning distance for each axis.

These parameters are valid for those axes for which bit 7 (KL2j) of parameter No. 16844 is set to 1.

Address	
16857	Time during which PF is set to 1 prior to end of positioning for first stage
16858	Time during which PF is set to 1 prior to end of positioning for second stage
16859	Time during which PF is set to 1 prior to end of positioning for third stage
16860	Time during which PF is set to 1 prior to end of positioning for fourth stage
16861	Time during which PF is set to 1 prior to end of positioning for fifth stage
16862	Time during which PF is set to 1 prior to end of positioning for sixth stage
16863	Time during which PF is set to 1 prior to end of positioning for seventh stage

Data type: Byte axis

Units of data: msec

Valid data range: 0 to  $\pm 120$

Set the time during which the press start signal PF is set to 1 prior to the end of the positioning corresponding to each positioning distance (PF early output function).

These parameters are valid for those axes for which bit 7 (KL2j) of parameter No. 16844 is set to 1.

Address	
16864	Rapid traverse rate for first stage
16865	Rapid traverse rate for second stage
16866	Rapid traverse rate for third stage
16867	Rapid traverse rate for fourth stage
16868	Rapid traverse rate for fifth stage
16869	Rapid traverse rate for sixth stage
16870	Rapid traverse rate for seventh stage

Data type: Two-word axis

Units of data:

Valid data range:

Increment system	Units of data	Valid data range
Millimeter machine	1 mm/min	30 to 240000
Inch machine	0.1 inch/min	30 to 96000
Rotary axis	1 deg/min	30 to 240000

Set the rapid traverse rate for each positioning distance, for each axis.

These parameters are valid for those axes for which bit 7 (KL2j) of parameter No. 16844 is set to 1.

Address	
16871	Rapid traverse time constant for first stage
16872	Rapid traverse time constant for second stage
16873	Rapid traverse time constant for third stage
16874	Rapid traverse time constant for fourth stage
16875	Rapid traverse time constant for fifth stage
16876	Rapid traverse time constant for sixth stage
16877	Rapid traverse time constant for seventh stage

Data type: Word axis

Units of data: msec

Valid data range: 8 to 4000

Set the rapid traverse time constant for each positioning distance, for each axis.

These parameters are valid for those axes for which bit 7 (KL2j) of parameter No. 16844 is set to 1.

Address	
16878	Positioning time for first stage (when rapid traverse override is 100% or 75%)
16879	Positioning time for second stage (when rapid traverse override is 100% or 75%)
16880	Positioning time for first stage (when rapid traverse override is 50% or 25%)
16881	Positioning time for second stage (when rapid traverse override is 50% or 25%)

Data type: Byte axis

Units of data: msec

Valid data range: 8 to 248

When using constant positioning time control, set the positioning time for the first and second stages, for each axis.

These parameters are valid for those axes for which both bits 7 (KL2j) and 6 (PT2j) of parameter No. 16844 are set to 1.

Address	
16882	Position gain for first stage
16883	Position gain for second stage
16884	Position gain for third stage
16885	Position gain for fourth stage
16886	Position gain for fifth stage
16887	Position gain for sixth stage
16888	Position gain for seventh stage

Data type: Word axis

Units of data:  $0.01 \text{ sec}^{-1}$

Valid data range: 1 to 9999

Set the positioning control servo loop gain corresponding to each positioning distance, for each axis.

These parameters are valid for those axes for which both bits 7 (KL2j) and 4 (LP2j) of parameter No. 16844 are set to 1.

# 12 PARAMETERS (2) FOR THE SAFETY ZONE

Address

16930	Positive X coordinate for safety zone 5
16931	Negative X coordinate for safety zone 5
16932	Y coordinate for safety zone 5
16933	Positive X coordinate for safety zone 6
16934	Negative X coordinate for safety zone 6
16935	Y coordinate for safety zone 6
16936	Positive X coordinate for safety zone 7
16937	Negative X coordinate for safety zone 7
16938	Y coordinate for safety zone 7
16939	Positive X coordinate for safety zone 8
16940	Negative X coordinate for safety zone 8
16941	Y coordinate for safety zone 8

Data type: Two-Word

Unit to data:

Increment system	IS-A	IS-B	Units
Millimeter machine	0.01	0.001	mm
Inch machine	0.001	0.0001	inch

Valid data range: 0 to  $\pm 99999999$ 

Each set of the parameters specify safety zone 5, 6, 7, or 8.

Refer to parameters No.16505 to No.16516.

These parameters are valid if the safety zone area extension function is specified.

**NOTE**

- 1 The values set for zone #n must be smaller than those set for zone #n + 1. (n: 1 to 7)
- 2 Zeros must be specified for zones which need not be specified.
- 3 If any of the +X, -X, and Y coordinates are set to 0 for an area, that area is invalid.

Address

16942	X dimension of tool area 13 for the safety zone function
16943	Y dimension of tool area 13 for the safety zone function
16944	X dimension of tool area 14 for the safety zone function
16945	Y dimension of tool area 14 for the safety zone function
16946	X dimension of tool area 15 for the safety zone function
16947	Y dimension of tool area 15 for the safety zone function
16948	X dimension of tool area 16 for the safety zone function
16949	Y dimension of tool area 16 for the safety zone function

Data type: Two-Word

Unit to data:

Increment system	IS-A	IS-B	Units
Millimeter machine	0.01	0.001	mm
Inch machine	0.001	0.0001	inch

Valid data range: 0 to 99999999

The parameters set 16 tool areas for the safety zone function.

Refer to parameters No. 16517 to No. 16532 and No. 16551 to 16558.

These parameters are valid if the safety zone area extension function is specified.

**NOTE**

A tool area is selected by signals SZTS0 to SZTS3 input from a PMC machine.

Address

16950	Width of workpiece holder 5 along the X-axis for automatic setting
16951	Width of workpiece holder 6 along the X-axis for automatic setting
16952	Width of workpiece holder 7 along the X-axis for automatic setting
16953	Width of workpiece holder 8 along the X-axis for automatic setting

Data type: Two-Word

Unit to data:

Increment system	IS-A	IS-B	Units
Millimeter machine	0.01	0.001	mm
Inch machine	0.001	0.0001	inch

Valid data range: 0 to 99999999

Each of the parameters specifies the width of a workpiece holder along the X-axis for the automatic setting of a safety zone by an external signal. The parameter values correspond to safety zones 5 to 8, specified in parameters 16930 to 16941, respectively.

Refer to parameters No.16540 to No.16543.

When automatic setting is executed, these parameters must be set.

These parameters are valid if the safety zone area extension function is specified.





## [A]

Additional Parameters for DI/DO Signals, 58

---

## [P]

Parameters For C-Axis Control, 40

Parameters for Cancelling Y-Axis Gap, 59

Parameters for the Function Used to Set Tool Data, 37

Parameters for the Nibbling Function, 24

Parameters for the Pattern Function, 27

Parameters for the Punch and Laser Switch, 32

Parameters (1) for the Safety Zone, 50

Parameters (2) for the Safety Zone, 71

Parameters for the Speed and Loop Gain Switch, 13

Parameters for the Turret Axis, 33

Parameters of the Press Function, 1

---

## [S]

Speed and Servo Parameter Switching Parameters, 62

---





